

Lambdatronic LT2 Sport

Quick Start Manual

Table of contents

1 Getting Started	3
2 Wiring	4
3 Heater Control Strategy	6
4 Lambda Sensor Installation and Environmental Considerations	7
5 Mounting and Environmental Considerations	10
6 Voltage Supply and Current Consumption	11
7 CAN Communications	12
7.1 Primary Data Message	12
7.2 Status and Diagnostic Message	13
7.3 LT2 Sport Config Message	16

1 Getting Started

The LT2 Sport provides controlled pumping current to supply up to two Bosch type LSU 4.9 lambda sensors. The lambda value, sensor status and diagnostics are available via CAN. The main features of this unit are the well established lambda measurement technologies of Bosch and attractive sport pricing.

The following supplies are required to use the LT2 Sport:

- One (or two) Bosch LSU 4.9 wide-band lambda sensors
- One LT2 Sport module
- LT2 Sport prebuilt wiring loom or one LT2 Sport connector kit and one (or two) LSU 4.9 connector kit(s) with related wiring supplies
- Engine controller, data logger or related CAN enabled device

These steps are recommended to get started with the LT2 Sport. Please note when power is provided to the LT2 Sport, it will automatically turn the lambda sensor heaters on after 30 seconds. The sensors become very hot so to avoid harm please verify sensors are installed in the exhaust and away from flammable objects.

- Verify the resistance across CANH and CANL is equal to 60 ohms with a multimeter when the system is powered off. If 60 ohms is not found check the CAN termination and refer to the wiring diagram in Fig. 3.
- Configure the CAN enabled device of choice to read the CAN messages from the LT2 Sport.
- Provide power to the LT2 Sport and verify CAN communications between the LT2 Sport and CAN enabled device.

2 Wiring

The pin layout is shown below looking in at the connector of the module. Part number for the LT2 Sport mating connector kit is F02U.V0U.150-01.

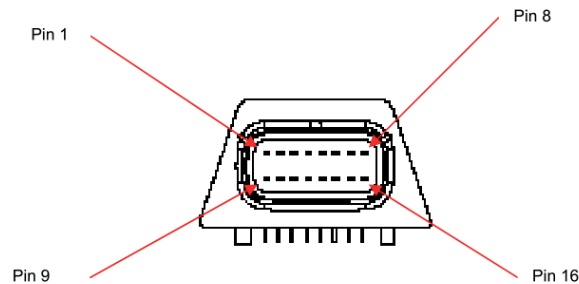

Fig. 1: Graphic from Wiring

Table 1 lists descriptions for each pin of the LT2 Sport. Some functions are duplicated because there are two sensors. A number follows the function acronym to indicate which sensor the pin is for. It is recommended to use 20 awg gauge wire for all pins on the LT2 Sport.

Pin	Function
1	12 V supply to heater (VS1)
2	12 V supply to heater (VS2)
3	CAN high (CANH)
4	nernst voltage (UN2)
5	pump current (IP2)
6	nernst voltage (UN1)
7	pump current (IP1)
8	heater control (RH2)
9	12 V supply to LT2 (UBATT)
10	ground (GND)
11	CAN low (CANL)
12	virtual ground (VM2)
13	setup current (IA2)
14	virtual ground (VM1)
15	setup current (IA1)
16	heater control (RH1)

Tab. 1: LT2 Sport Pinout Information

The following image gives the pin layout of the LSU 4.9 connector.

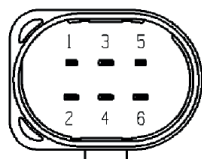

Fig. 2: LSU 4.9 Connector

Table 2 lists descriptions for each pin of an LSU 4.9. It is recommended to use twisted pair wiring for all pins listed with a paired pin.

Pin	Function
1	pump current (IP)
2	virtual ground (VM)
3	heater control (RH)
4	12 V supply to heater (VS)
5	setup current (IA)
6	nernst voltage (UN)

Tab. 2: LSU 4.9 Wide Band Lambda Sensor Pinout

It is recommended to use twisted pair wiring for all pins listed in the following table. This helps to reduce noise on the lambda signal. The following pairs should be twisted for each LSU and for the CAN bus.

Pair 1	Pair 2
CAN high (CANH)	CAN low (CANL)
nernst voltage (UN)	virtual ground (VM)
pump current (IP)	setup current (IA)

Tab. 3: LT2 Sport twisted Pairs

The LT2 Sport does not include CAN termination on board. Proper CAN termination must be included in the wiring harness at each end of the bus. A daisy chain style bus must be constructed with stub lengths for added devices kept to less than 1 foot (0.3 meters). Figure 3 shows a correctly constructed CAN bus with termination. Shielding is not required and the LT2 Sport does not offer a shield pin. However, if another module on the CAN bus offers a shield pin it is recommended to use it.

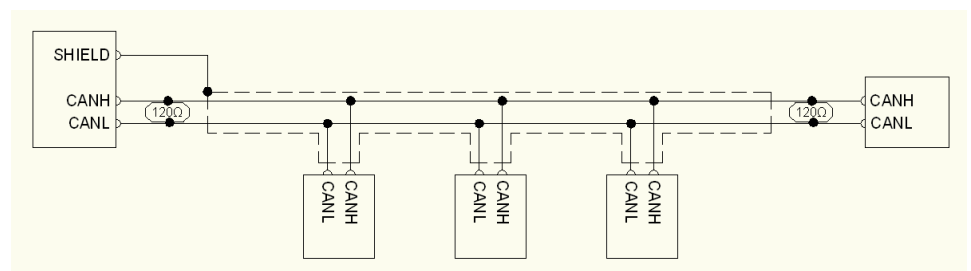

Fig. 3: Example of correctly configured CAN bus

3 Heater Control Strategy

The LSU 4.9 can be damaged by condensation in the exhaust contacting the ceramic heater of the sensor. It is recommended to not turn on the sensor heater until all condensation in the exhaust has evaporated.

By default, the LT2 Sport does not turn the LSU 4.9 sensor element heaters on for the first 30 seconds of operation unless a CAN message is sent to turn the heaters on. This simple time based strategy is automatically used if the LT2 Sport config message is not sent on the bus.

A more advanced strategy can be utilized where the heaters can be further delayed via CAN. By sending the LT2 Sport config message with the heater off command at system powerup the LT2 Sport will wait for a heater command on CAN. After the engine has run for some time the LT2 Sport config message can then be sent to enable the heaters. For further information see the LT2 Sport config message section.

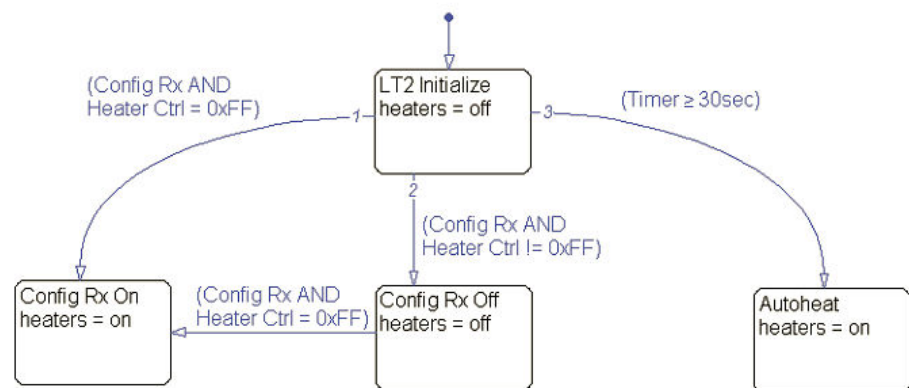

Fig. 4: CAN Messages Heater Control Strategy

4 Lambda Sensor Installation and Environmental Considerations

Care must be taken when mounting the lambda sensor to avoid damage and ensure accuracy. Ideally the sensor should be mounted vertically with the wiring above the sensor. The following diagrams show how the sensor mounting can vary slightly from vertical. They also show how the sensor must be mounted in relation to exhaust flow. If the sensor is mounted upside down damage to the sensor is likely.

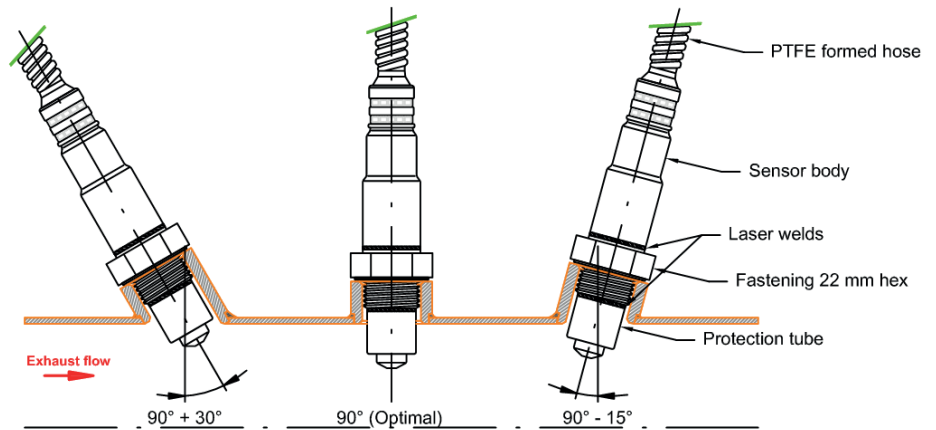

Fig. 5: Lambda Sensor Installation Diagram, Part 1

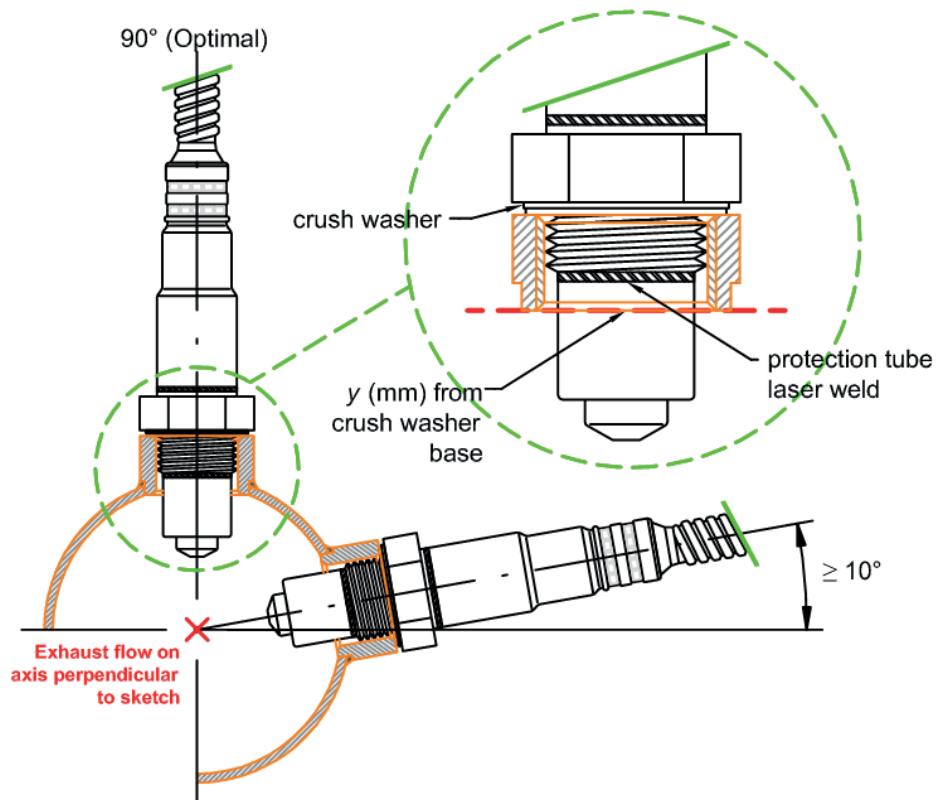

Fig. 6: Lambda Sensor Installation Diagram, Part 2

The PTFE formed hose is part of the reference air volume of the sensor and must be kept sealed and undamaged. For installation, the minimum bending radius of the hose must be 20 mm (for long PTFE hose) resp. 12 mm (for short hose). Keep the PTFE formed hose away from sharp edges and avoid contact/ friction with frame/engine assembly. The first fixing point for the cable to the car body should be 200 mm to 400 mm after the end of the PTFE formed hose, depending on movement of the exhaust system.

The LSU 4.9 can read incorrectly or be damaged when high exhaust gas temperatures are present. The following specifications must be met to maintain signal accuracy and sensor life.

Exhaust Gas Temperature	≤930°C
Sensor Hexagon Temperature	≤600°C
Sensor Side Grommet Temperature	≤250°C
Cable Side Grommet Temperature	≤200°C
Sensor Sleeve Temperature	≤250°C
Sensor Connector Temperature	≤140°C

The sensor can handle further extreme temperature for a shortened amount of time.

Max 250 hours over sensor life

Exhaust Gas Temperature	≤1,030°C
Sensor Hexagon Temperature	≤680°C

Max 40 hours over sensor life

Sensor Side Grommet Temperature	≤280°C
Cable Side Grommet Temperature	≤230°C
Sensor Sleeve Temperature	≤280°C
Sensor Connector Temperature	≤150°C

The following diagram shows the thread boss dimensions in metric units.

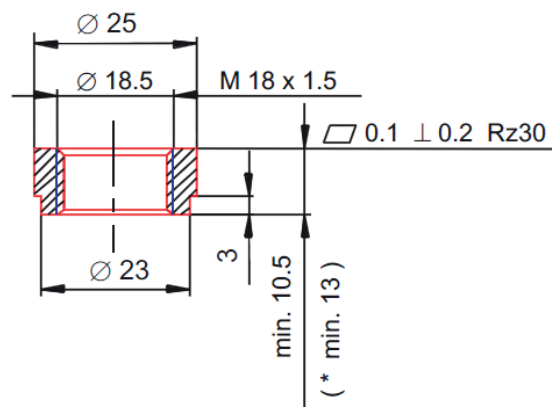

Fig. 7: Lambda Sensor thread boss Dimensions

Recommended material for the thread boss is temperature resistant stainless steel, e. g. X 5 CrNi 18 10, DIN 17440 1.4301 or 1.4303 or SAE 30304 or SAE 30305 (US standard). Thread boss dimensions should match the dimensions in the drawing. Note that the sensor thread must be covered completely.

Recommendation(*): For hot applications (sensor hexagon temp > 600°C or exhaust gas temp > 930°C) the thread boss should be a minimum of 13 mm to avoid overheating of the protection tube welding and to cool down the sensor hexagon. If the length is ≥ 16 mm (max. 22 mm permissible) the danger of thermo shock will be increased due to condensation water formation inside the protection tube.

Exhaust back pressure can also impact the LSU 4.9 accuracy and can even damage the sensor if pressure is high enough. The following must be maintained to not damage the sensor.

Exhaust Gas Pressure	≤ 2.5 bar
----------------------	----------------

5 Mounting and Environmental Considerations

The following specifications should be considered for LT2 Sport vehicle mounting.

Min Temperature	-40°C
Max Temperature	+85°C
Short Duration Max	+120°C for max 30 minutes
Max Vibration	11 ms 30 G peak sawtooth wave

The LT2 Sport can be mounted underhood and is splash proof. Vibration isolation is recommended for LT2 Sport mounting.

6 Voltage Supply and Current Consumption

The following specifications should be considered for wire and circuit selection.

Supply Voltage	9.5 V – 16.5 V
Nominal Voltage	13.5 V
Max Current draw	10 amps (simultaneous heating of both sensors)
Average Current draw	4 amps

The LT2 Sport offers overvoltage protection with the following specifications.

Supply Voltage	24 V
Duration	5 minutes max
Ambient Temperature	23°C

The LT2 Sport offers reverse battery protection with the following specifications.

Supply Voltage	-16 V
Duration	5 minutes max
Ambient Temperature	23°C

The LT2 Sport offers load dump protection with the following specifications.

Max Supply Voltage	32 V
Duration	<400 ms
Ambient Temperature	23°C

7 CAN Communications

The LT2 Sport transmits four messages and receives one for configuration and control purposes. There are two messages per sensor. The first contains primary sensor information and the second contains detailed status and diagnostic information. The module is shipped with a baud rate of **1,000 kbits/sec**. Please note that the module baud rate must match the bus baud rate. Mismatched baud rates can crash the entire bus. To configure the baud rate it is recommended that no other modules be on the bus to avoid mismatched baud rates during configuration.

7.1 Primary Data Message

ID	0 x 460 / 0 x 461 (default setting for sensor 1 / 2, however the IDs can be re-configured)
ID type	Standard (11 bit identifier)
Direction	Transmit from LT2
Length	8 bytes
Rate	10 ms
Byte	Function
Byte 0	Row Count = 0
Byte 1	Lambda
Byte 2	
Byte 3	Pump Current
Byte 4	
Byte 5	N/A
Byte 6	Fault
Byte 7	Heater PWM
Lambda (no units)	
Byte 1	MSB
Byte 2	LSB
Endianess	Motorola (big-endian)
Type	Unsigned
Factor	0.001
Offset	0
Pump Current (amps)	
Byte 3	MSB
Byte 4	LSB
Endianess	Motorola (big-endian)
Type	Signed

Pump Current (amps)	
Factor	0.000001
Offset	0
Fault (bit mask)	
Type	Unsigned
Factor	1
Offset	0
Bit 0	Heater short to ground
Bit 1	Heater short to ubatt
Bit 2	Heater open circuit
Bit 3	Heater failed to heat sensor
Bit 4	Sensor wire/circuit error
Heater PWM (duty cycle %)	
Type	Unsigned
Factor	1
Offset	0

7.2 Status and Diagnostic Message

ID	0 x 460 / 0 x 461 (default setting for sensor 1 / 2, however the IDs can be re-configured)
ID type	Standard (11 bit identifier)
Direction	Transmit from LT2
Length	8 bytes
Rate	100 ms
Byte	Function
Byte 0	Row Count = 1
Byte 1	LSU State
Byte 2	Stat B3
Byte 3	Stat B4
Byte 4	Stat B5
Byte 5	Stat B6
Byte 6	Stat B7
Byte 7	SW Ver
LSU State (enumeration)	
Type	Unsigned
Factor	1
Offset	0

LSU State (enumeration)	
= 0	Start Up / Other
= 6	Heating
= 7	Operating Normally
= 8	Cooling
Stat B3 (enumeration)	
Type	Unsigned
Factor	1
Offset	0
<i>Bit 0 – Bit 1</i>	<i>Supply Voltage Status</i>
= 0	Voltage not in range
= 1	Voltage in range
= 2	Voltage error
<i>Bit 2 – Bit 3</i>	<i>Sensor Temperature Status</i>
= 0	Sensor not at Temperature
= 1	Sensor at Temperature
= 2	Sensor Temperature error
<i>Bit 4 – Bit 5</i>	<i>Heater Mode</i>
= 0	Autoheating
= 1	Preheat2
= 2	Preheat1
= 3	Heater off
<i>Bit 6 – Bit 7</i>	<i>Lambda Stability</i>
= 0	Lambda not stable
= 1	Lambda stable
= 2	Stability error
Stat B4 (enumeration)	
Type	Unsigned
Factor	1
Offset	0
<i>Bit 0 – Bit 1</i>	<i>Heater resistance diagnostic</i>
= 0	Diag not run
= 1	Diag pass
= 2	Diag fail
<i>Bit 2 – Bit 3</i>	<i>Heater circuit short high diagnostic</i>
= 0	Diag not run
= 1	Heater not shorted high
= 2	Heater shorted high
<i>Bit 4 – Bit 5</i>	<i>Heater circuit short low diagnostic</i>

Stat B4 (enumeration)	
= 0	Diag not run
= 1	Heater not shorted low
= 2	Heater shorted low
<i>Bit 6 – Bit 7</i>	
<i>Heater open circuit diagnostic</i>	
= 0	Diag not run
= 1	Heater not open circuit
= 2	Heater open circuit
Stat B5 (enumeration)	
Type	Unsigned
Factor	1
Offset	0
<i>Bit 0 – Bit 1</i>	
<i>Heater performance diagnostic</i>	
= 0	Diag not run
= 1	Heater performance ok
= 2	Heater performance fail
Stat B6 (enumeration)	
Type	Unsigned
Factor	1
Offset	0
<i>Bit 0 – Bit 1</i>	
<i>LT2 internal diagnostic</i>	
= 0	Diag not run
= 1	Internal diag pass
= 2	Internal diag fail
<i>Bit 2 – Bit 3</i>	
<i>Sensor circuit short high diagnostic</i>	
= 0	Diag not run
= 1	Sensor not shorted high
= 2	Sensor shorted high
<i>Bit 4 – Bit 5</i>	
<i>Sensor circuit short low diagnostic</i>	
= 0	Diag not run
= 1	Sensor not shorted low
= 2	Sensor shorted low
<i>Bit 6 – Bit 7</i>	
<i>Sensor open circuit diagnostic</i>	
= 0	Diag not run
= 1	Sensor not open circuit
= 2	Sensor open circuit
Stat B7 (enumeration)	
Type	Unsigned
Factor	1

Stat B7 (enumeration)	
Offset	0
<i>Bit 0 – Bit 1</i>	<i>UN open circuit diagnostic</i>
= 0	Diag not run
= 1	UN not open circuit
= 2	UN open circuit
<i>Bit 2 – Bit 3</i>	<i>IP open circuit diagnostic</i>
= 0	Diag not run
= 1	IP not open circuit
= 2	IP open circuit
<i>Bit 4 – Bit 5</i>	<i>Not used</i>
<i>Bit 6 – Bit 7</i>	<i>IA open circuit diagnostic</i>
= 0	Diag not run
= 1	IA not open circuit
= 2	IA open circuit
SW Ver (Software Version)	
Type	Unsigned
Factor	1
Offset	0
Simple software version counter starting at 1.	

7.3 LT2 Sport Config Message

ID	0 x 18FEDF00
ID type	Extended (29 bit identifier)
Direction	Transmit LT2
Length	8 bytes
Rate	n/a
Byte	Function
Byte 0	Mode
Byte 1	Data1
Byte 2	Data2
Byte 3	Data3
Byte 4	Data4
Byte 5	Data5
Byte 6	Data6
Byte 7	Heater Ctrl
Mode (enumeration)	
Type	Unsigned

Mode (enumeration)	
Factor	1
Offset	0
<i>= 0 x AA</i> <i>Configure CAN IDs</i>	
Data1	ID1 MSB (partial byte)
Data2	ID1 LSB
Data3	ID2 MSB (partial byte)
Data4	ID2 LSB
Data5	Not used
Data6	Not used

The CAN ID is 11 bits so the most significant byte of the config message is used to only represent the 3 most significant bits of the ID. If Data2 or Data4 are set greater than 7 the ID will not be set as expected.

<i>= 0 x BB</i> <i>Reset CAN IDs to default</i>	
Data1	Not used
Data2	Not used
Data3	Not used
Data4	Not used
Data5	Not used
Data6	Not used

<i>= 0 x CC</i> <i>Set baud rate</i>	
Data1	Not used
Data2	Not used
Data3	Not used
Data4	Not used
Data5	25, 50 or 100
Data6	Not used

1,000 k = 100 or 0 x 64

500 k = 50 or 0 x 32

250 k = 25 or 0 x 19

<i>= 0 x DD</i> <i>Reset baud rate to default (1,000 k)</i>	
Data1	Not used
Data2	Not used
Data3	Not used
Data4	Not used
Data5	Not used
Data6	Not used

Heater Ctrl (enumeration)	
Type	Unsigned
Factor	1
Offset	0
= 0 x FF	Turn heaters on
! = 0 x FF	Not used

Only 0 x FF will turn the heaters on, all other values have no effect. If the LT2 Sport does not receive this message the heaters automatically turn on after 30 seconds. Once the message is received once auto heater turn on is disabled and byte 7 must be set to 0 x FF to turn the heaters on. Reference the state diagram in the heater control strategy section to see the possibilities to control the heaters.

Bosch Engineering North America

Motorsports

38000 Hills Tech Drive

Farmington Hills, MI 48331-3417

United States of America

www.bosch-motorsport.com
