

Ignition Module IM 3.2

www.bosch-motorsport.com



BOSCH
Invented for life



- ▶ Max. 3 cylinders
- ▶ 47 g
- ▶ Fits to all ECUs without internal ignition power stage like MS 6
- ▶ Especially adapted for Coils P50(-M) and P65

This module is an external ignition power stage capable of supplying up to three non-transistorized ignition coils.

The IM input signal should be supplied by an ECU with ignition signal outputs in the range of 10 to 20 mA, e.g. MS 4 Sport.

The IM unit combines the robustness of a high quality production part with good electrical performance to provide an ideal solution for adapting non-transistorized coils to an ECU without internal ignition driver stages.

Application

Primary current	≤ 8.5 A
Clamp voltage	380 ± 30 V
Operating temperature range at measuring point	-40 to 120°C
Storage temperature range	-40 to 130°C
Max. rpm (ensure chilled mounting position)	8,000
Max. vibration	400 m/s ² at 5 to 2,500 Hz

Technical Specifications

Mechanical Data

Size	71 x 48 x 21 mm
Weight w/o wire	47 g
Mounting	2 x M4 screws with spring washer
Operating temperature	-40 to 110°C
Permissible fuel temperatures	≤ 70°C

Electrical Data

U _{Batt} typical	13.5 V
Voltage supply	6 to 16.5 V
I _b high active on	min. 10 mA
I _b low off	0 mA
I _B	10 to 22 mA
I _C typical	≤ 8.5 A
I _C max. at T _U < 120°C	< 10 A
U _{CE} satt at I _C = 5 A	< 3 V
U _{CE} satt at I _C max	< 9 V

Characteristic

Characteristic dwell time	See characteristic dwell time from the ignition coil used
Internal transistor	Triple Darlington

Connectors and Wires

Connector	Bosch Jetronic 7-pole
Mating connector 7-pole Jetronic	F 02U B00 252-01
Pin 1	Collector transistor 1
Pin 2	Basis transistor 1
Pin 3	Collector transistor 2
Pin 4	Gnd
Pin 5	Basis transistor 2
Pin 6	Collector transistor 3
Pin 7	Basis transistor 3

Installation Notes

This ignition module can be used with Coils PS, P35, P50(-M), P65, 2x1, 2x2, 3x2 or comparable coils.

Please ensure that the connectors are safe from water.

The IM has to be mounted onto a cooling body. The mounting surface needs a planarity of 0.2 mm.

A heat conductive paste has to be used.

This ignition module is designed for use with engine control units which have no integrated ignition transistor.

Please observe the specified limit values.

Please do not activate more than one ignition output stage parallel within a module.

Please find further application hints in the offer drawing at our homepage.

Ordering Information**Ignition Module IM 3.2**

Order number **0 227 100 203**

Dimensions

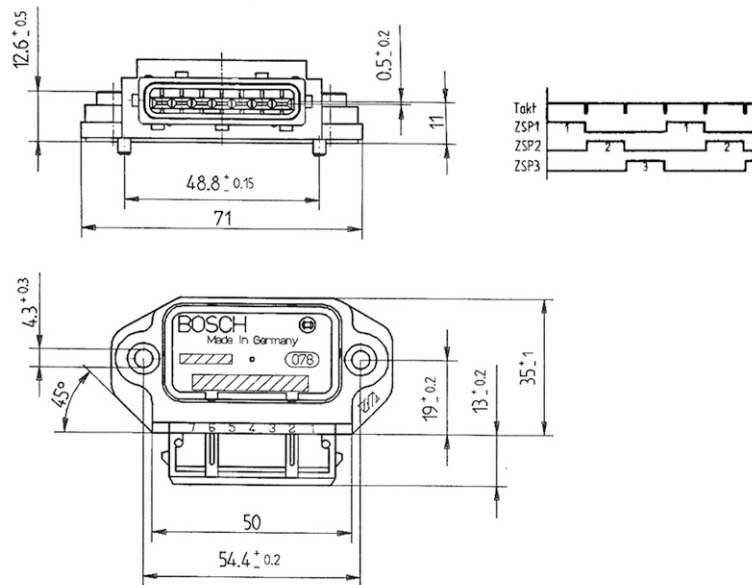
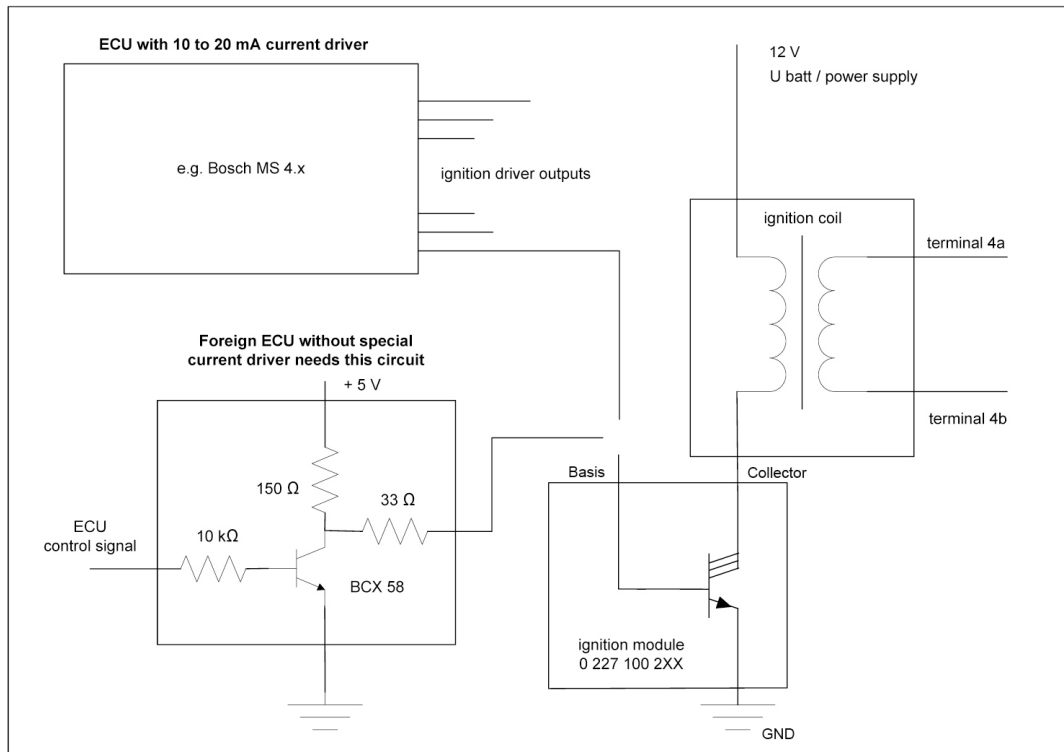

Represented by:

Europe:

Bosch Engineering GmbH
Motorsport
Robert-Bosch-Allee 1
74232 Abstatt
Germany
Tel.: +49 7062 911 9101
Fax: +49 7062 911 79104
motorsport@bosch.com
www.bosch-motorsport.de

North America:

Bosch Engineering North America
Motorsport
38000 Hills Tech Drive
Farmington Hills, MI 48331-3417
United States of America
Tel.: +1 248 876 2977
Fax: +1 248 876 7373
motorsport@bosch.com
www.bosch-motorsport.com

Latin America:

Robert Bosch Ltda
Motorsport
Av Juscelino Kubitscheck de
Oliveira 11800
Zip code 81460-900
Curitiba - Parana
Brasilia
Tel.: +55 41 3341 2057
Fax: +55 41 3341 2779

Asia-Pacific:

Bosch Engineering Japan K.K.
Motorsport
18F Queen's Tower C, 2-3-5 Minato Mirai
Nishi-ku, Yokohama-shi
Kanagawa 220-6218
Japan
Tel.: +81 45 650 5610
Fax: +81 45 650 5611
www.bosch-motorsport.jp

Australia, New Zealand and South Africa:

Robert Bosch Pty. Ltd
Motorsport
1555 Centre Road
Clayton, Victoria, 3168
Australia
Tel.: +61 (3) 9541 3901
motor.sport@au.bosch.com