

Lap Trigger HF 24

This lap trigger system HF 24 consists of a high frequency transmitter station and a receiver which is installed in the car.

The system allows an exact lap time measurement. Section time measurement for comparison of different car setups is also available if several transmitters are used. We offer optionally a tripod for mounting the transmitter anywhere along the race track.



Mechanical Data

HF 24 Receiver

Size 125 x 37 x 28 mm

Weight 130 g

Internal antenna with radome

Aluminium housing

HF 24 Transmitter

Size 290 x 118 x 93 mm

Weight 1880 g

Tripod

Maximum height ~ 150 cm

Minimum height ~ 65 cm

Weight 1370 g

Conditions of Use

Working range up to 50 m

Ambient temperature -10 ... 85 °C

Power consumption HF 24 Receiver 0,8 W

Power consumption HF 24 Transmitter 1 W

Electrical Data

System

RF wideband chirp transmission

Working frequency band 2,40 ... 2,47 GHz

User codes 16

HF 24 Receiver

Sensitivity -92 dBm @ BER 10⁻³; 1 Mbps

Supply voltage 6,5 ... 30 V

Connector type ASL 606-05PD-HE

Pin 1 +12 V

Pin 2 GND

Pin 3 Trigger Out

Mechanical drawing Y 261 A25 087

HF 24 Transmitter

Transmission power 10 dBm

Transmitter antenna flat panel

Supply voltage 10 ... 30 V

Supply current 90 mA

Selection main / sub trigger

Low battery detection

Mechanical drawing Y 261 A25 038

Application Hints

HF 24 Transmitter

Before setting the main switch to ON, select the code and the working mode (main / sub trigger).

The transmitter reads the switches for code and main / sub trigger only once at power up.

After setting the main switch to ON the transmitter executes a 10 sec. self test and then the transmitter indicator begins to flash green, e.g. the transmitter is running.

The battery condition is permanently checked. If the battery level becomes critical, the "low bat indicator" becomes red. When the battery level drops below 10 V, the transmitter stops working. The green transmitter indicator stops flashing.

The transmitter should be placed at the border of the lane in a height of about 1.5 ... 2.0 m.

HF 24 Receiver

Before switching on the DC power the code has to be selected.

After switching ON the receiver executes a 10 sec. self test and then it turns into the working mode.

When a trigger is detected the output pin goes low for a certain time:

-20 msec low @ main trigger

-40 msec low @ sub trigger

Standard output configuration:

low side switch with $R = 3.3 \text{ k}\Omega$ (*) to +5 VDC
(*) can be modified according to user demands

The white antenna radome must be turned to the transmitter side and should not be mounted behind metallic covers or carbon fiber filled elements.

Green indicator flashes when it detects a trigger condition.

Function Description

The transmitter sends via the directional antenna coded signals across the race track.

The receiver at the race car checks permanently the team code and the signal parameters. If the trigger condition is detected the receiver generates the appropriate output signal (main/sub trigger).

The trigger point is located at broadside of the transmitter antenna.

After detecting the trigger point and releasing the trigger signal the receiver is passive for a period of two seconds avoiding a multiple trigger signal.

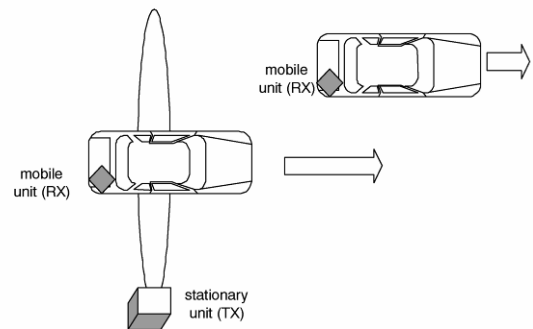

Part Numbers

HF 24 Receiver	B 261 206 894-01
HF 24 Transmitter	B 261 206 895-01
Tripod	B 261 206 897