

Injection Valve EV 14i

EV 14i injection valves are developed specially for motorsport applications.

The injection valve EV 14i is designed for a wide range of flow rates and spray patterns. Very compact size simplifies mounting in a variety of applications.



Application	
Fuel input	axial (top-feed)
Operating temperature	-40 ... 110 °C
Permissible fuel temperatures	≤ 70 °C
Climate-proof corresponding to saline fog test DIN 50 021	

Mechanical Data	
System pressure	max. 8 bar
Weight	≤ 20 g
Installation lengths	26.9 mm

Electrical Data	
Max. power supply	16 V

Characteristic	
Housing design	very compact
Connectors	some motorsport connectors
Spray type	C (single beam) or E (twin beam)
Flow rate at 3 bar	up to 1,023 cm ³ /min
Flow rate at 3 bar	up to 700 g/min (n-heptane)
Spray angle α	15° ... 85°
Bent angle γ	0° ... 15°
Coil resistance	2.3 Ω or 12 Ω

Application Hint	
Please ask for more information before ordering.	
Injectors with low resistance are only supplied with a peak and hold power stage.	

Some examples for EV 14i							
Flow rate at 3 bar (n-heptane) [g/min]	Flow rate at 3 bar [cm ³ /min]	Design	Type	Spray angle α 80	Bent angle γ	Coil resistance	Part number
213	311	i	C	80°	0°	12 Ω	on request
261	382	i	C	25°	0°	2.3 Ω	on request
261	382	i	C	35°	0°	2.3 Ω	on request
261	382	ixT	E	20°	15°	12 Ω	on request
261	382	i	C	35°	0°	12 Ω	F 02U V00 718-01
261	382	i	E	20°	0°	12 Ω	F 02U V00 724-01
310	453	i	C	35°	0°	12 Ω	on request

Further spray angles and flow rates are available on request.

Spray Illustration

C: Conical Spray

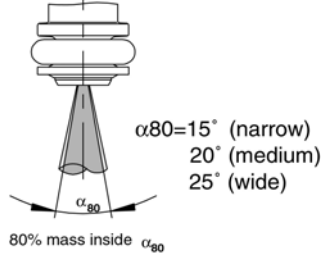

E: 2-Spray

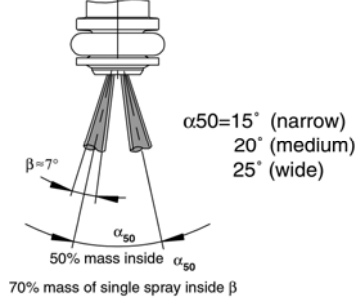

Angle between connection and spray level ($\delta = \text{delta}$):
 (only 2-spray preparation)

$\delta = 0^\circ - 360^\circ$ possible

