

Lean Angle Sensor LAS-1

This sensor is designed to measure the acceleration and the rate of turn in two axis (yaw rate Ω_z , roll rate Ω_x , lateral acceleration a_y and longitudinal acceleration a_z).

An internal diagnosis indicates too high vibrations or turning rates.

In combination with a MS 5 ECU and its algorithm a very precise lean angle of motorcycles can be calculated.

The main feature and benefit of this sensor is its wide measuring range, the standardized 1 Mbaud CAN-signal output and the combination of high quality production part and robust design.



Application	
Application I	± 163 °/s (roll rate/yaw rate)
Application II	± 4.1 g (X and Y acceleration)
Operating temperature range	-20 ... 85 °C

Electrical Data	
Power supply	7 ... 18 V
Max input current	200 mA
Power up time	< 150 ms

Connectors and Wires	
Connector	AMP 114-18063-076
Mating connector	F 02U B00 240-01
Pin 1	GND
Pin 2	CANL
Pin 3	CANH
Pin 4	UBAT

Mechanical Data	
Weight w/o wire	96 g
Size	33 x 98 x 91 mm

Characteristic Application I	
Measuring range	± 160 °/s
Overrange limit	$\pm 1,000$ °/s
Absolute resolution	0.1 °/s
Cut-off frequency (-3 dB)	15 Hz

Characteristic Application II	
Measuring range	± 4.1 g
Overrange limit	± 10 g
Absolute resolution	0.01 g
Cut-off frequency (-3 dB)	15 Hz

CAN Parameters

Byte order	Little endian, high-byte/low-byte, Intel
CAN speed	1 Mbaud
CAN refresh rate	10 ms
Identifier length	11 bit
Bit mask	signed
Offset (all signals)	0x8000 hex
Quantisation Yaw Rate	0.005 [°/s/digit]
Quantisation Roll Rate	0.005 [°/s/digit]
Quantisation Acc X-Axis	0.0001274 [g/digit]
Quantisation Acc Y-Axis	0.0001274 [g/digit]
Conversion formula	
Yaw rate [°/s] = (Hex-value – 8000 h) * 0.005 [°/s/digit]	
Roll rate [°/s] = (Hex-value – 8000 h) * 0.005 [°/s/digit]	

Application Hint

Important: In order not to exceed the maximum vibration level, the mount should be damped and not resonate.

For measuring the yaw and roll rate the LAS-1 can be connected directly to most control units and data logging systems.

The lean angle of motorcycles can be calculated in a MS 5 with motorcycle functionality.

Please avoid abrupt temperature changes.

For mounting please use only the integrated fixing holes.

Please ensure that the environmental conditions do not exceed the sensor specifications.

Please find further application hints in the offer drawing (<http://www.bosch-motorsport.com>).

Part Number

Lean Angle Sensor LAS-1

F 02U V00 657-01

CAN Message

CAN_ID_01 0x174

Byte	0	1	2	3	4	5	6	7
Value	Yaw Rate		Yaw_STAT	Reserved	Acc Y		AccY_STAT	Unused

CAN_ID_02 0x178

Byte	0	1	2	3	4	5	6	7
Value	Roll Rate		Roll_STAT	Reserved	Acc X		AccX_STAT	Unused

Bit combination of sensor status

Yaw_STAT, Roll_STAT, AccY_STAT and AccX_STAT:

xx00 xxxx = signal in specification

xx01 xxxx = sensor not available

xx10 xxxx = signal failure

xx11 xxxx = reserved

x1xx xxxx = initialisation is running

x0xx xxxx = initialisation is ready

1xxx xxxx = reserved

0xxx xxxx = reserved

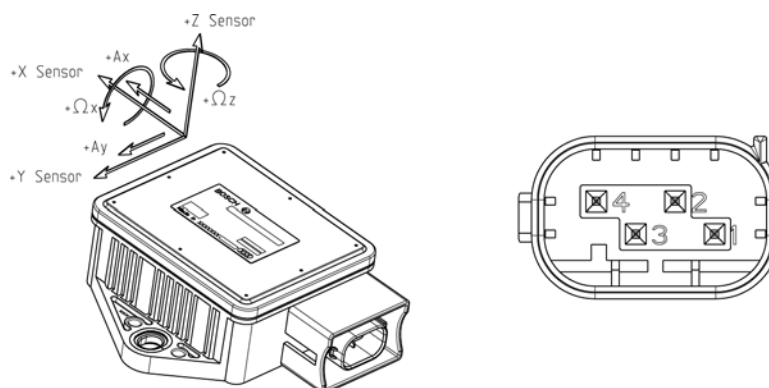



BOSCH

