

Knock Sensor KS4-R



- ▶ Frequency: 3 to 25 kHz
- ▶ Weight: 82 g
- ▶ Height sensor head: 18 mm

This sensor is used for detecting structural born vibrations in spark ignition engines due to uncontrolled combustion. This sensor is suitable for operation in extreme conditions.

Due to the inertia of the seismic mass, the sensor moves in correlation to the engine block vibration; this motion results in a compressive force which is converted into a voltage signal via a piezoceramic sensor element. As a result, upper and lower voltage thresholds can be defined directly correlating to an acceleration magnitude.

The main benefits of this sensor are its robust mechanical design, compact housing and precise determination of structure-related noise. Connection to this sensor can be tailored to customer requirements through specified wire lengths and various connector options.

Application

Application	3 to 25 kHz
Operating temperature range	-40 to 130°C
Storage temperature range	-30 to 60°C
Max. vibration	≤ 800 m/s ²

Technical Specifications

Mechanical Data

Male thread (for cast)	M8x25
Male thread (for Al)	M8x30
Installation torque	20 ± 5 Nm
Weight w/o wire	82 g
Protection	IP 54

Electrical Data

Range of frequency	3 to 25 kHz
Sensitivity at 5 kHz	28.8 mV/g
Max. sensitivity changing (lifetime)	-17 %
Linearity between 5 to 15 kHz (from 5 kHz value)	-10 to 10 %
Linearity between 15 to 20 kHz (linear increasing with freq)	20 to 50 %
Main resonance frequency	> 30 kHz
Impedance	> 1 MOhm
Temperature dependence of sensitivity	0.04 mV/g°C
Capacity field	1,150 ± 200 pF

Connectors and Wires

Connector	A 261 230 252
Mating connector 2-pole	2-Pin RB-Kp.1 (D261.205.337-01), L=530 mm or 2-Pin RB-Kp.3 (F02U.B00.967-01), L=400 mm
Pin 1	Sig +
Pin 2	Sig -
Sleeve	PUR
Wire size	0.5 mm ²
Wire length L	See Ordering Information
Various motorsport and automotive connectors on request.	

Installation Notes

The KS4-R can be connected to all Bosch Motorsport ECUs featuring knock control

The sensor must rest directly on the brass compression sleeve during operation.

To ensure low-resonance coupling of the sensor to the measurement location, the contact surface must be clean and properly machined to provide a secure flush mounting.

Please route the sensor wire in a way that prevents resonance vibration.

Please find further application hints in the offer drawing at our homepage.

Safety Note

The sensor is not intended to be used for safety related applications without appropriate measures for signal validation in the application system.

Legal Restrictions

Due to embargo restrictions, sale of this product in Russia, Belarus, Iran, Syria, and North Korea is prohibited.

Ordering Information

Knock Sensor KS4-R

Mating Connector 2-Pin RB-Kp.1, L = 530 mm
Order number **0261.231.218**

Knock Sensor KS4-R

Mating Connector 2-Pin RB-Kp.3, L = 400 mm
Order number **0261.231.223**

Dimensions

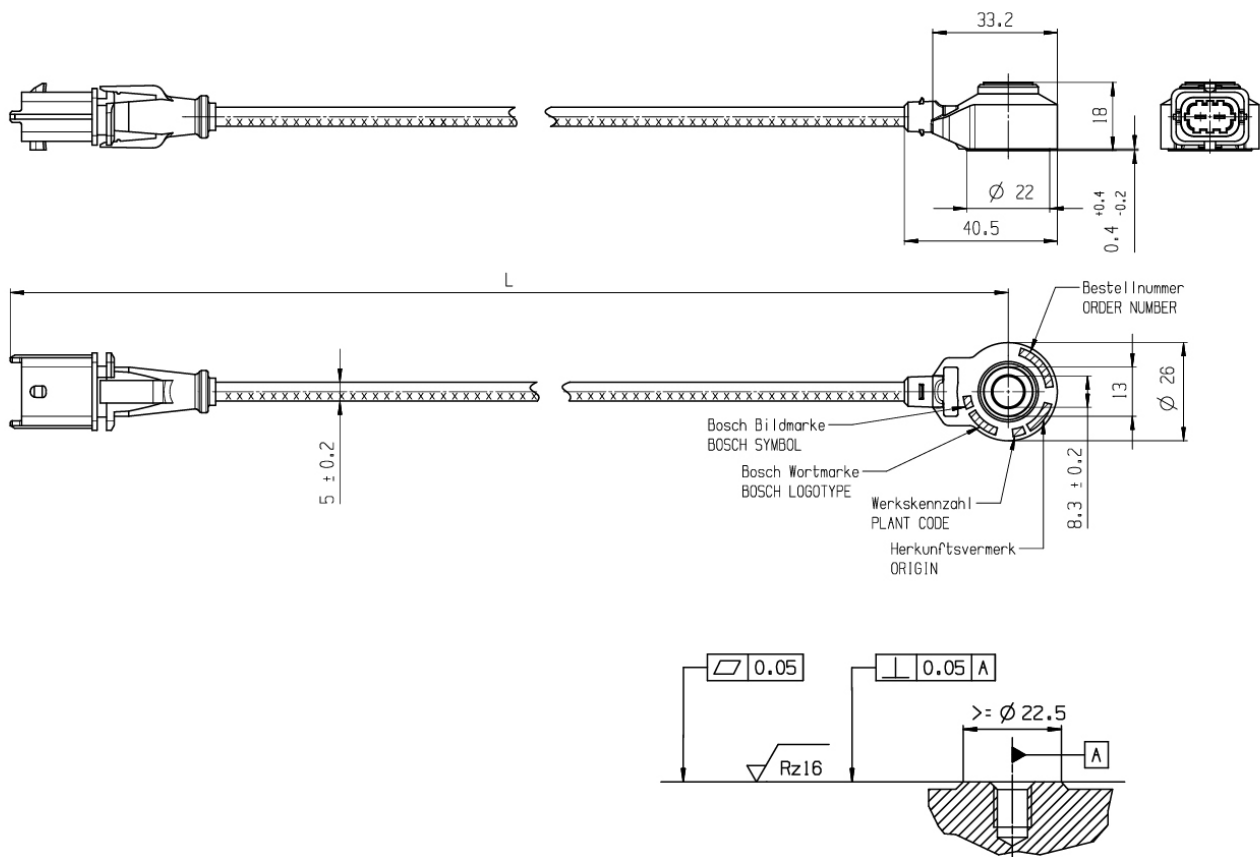

Represented by:

Europe:
Bosch Engineering GmbH
Motorsport
Robert-Bosch-Allee 1
74232 Abstatt
Germany
Tel.: +49 7062 911 9101
Fax: +49 7062 911 79104
motorsport@bosch.com
www.bosch-motorsport.de

North America:
Bosch Engineering North America
Motorsport
38000 Hills Tech Drive
Farmington Hills, MI 48331-3417
United States of America
Tel.: +1 248 876 2977
Fax: +1 248 876 7373
motorsport@bosch.com
www.bosch-motorsport.com

Asia-Pacific:
Bosch Engineering Japan K.K.
Motorsport
18F Queen's Tower C, 2-3-5 Minato
Mirai Nishi-ku, Yokohama-shi
Kanagawa 220-6218
Japan
Tel.: +81 45 650 5610
Fax: +81 45 650 5611
www.bosch-motorsport.jp

Australia, New Zealand and South Africa:
Robert Bosch Pty. Ltd
Motorsport
1555 Centre Road
Clayton, Victoria, 3168
Australia
Tel.: +61 (3) 9541 3901
motor.sport@au.bosch.com