

Lambda Sensor LSU ADV



This sensor is designed to measure the proportion of oxygen in exhaust gases of automotive engines (gasoline or Diesel).

The wide band lambda sensor LSU ADV is a planar ZrO_2 dual cell limiting current sensor with integrated heater. Its monotonic output signal in the range of lambda 0.65 to air makes the LSU ADV capable of being used as a universal sensor for lambda 1 measurement as well as for other lambda ranges.

The LSU ADV has no trimming resistor inside the connector what results in just 5 connector pins. Compared to LSU 4.9, the LSU ADV has a wider working temperature range.

LSU ADV operates only in combination with a special evaluation unit used in lambda control unit LT4 ADV. You'll find this unit and more on our homepage at Electronics/Sensor Interfaces.

Application

Application	lambda 0.65 to ∞
Fuel compatibility	gasoline/Diesel/E85
Exhaust gas pressure	≤ 2.5 bar (higher with decrease accuracy)
Exhaust gas temperature (operating)	$\leq 930^\circ\text{C}$
Max. exhaust gas temperature for short time	$\leq 1,030^\circ\text{C}$
Hexagon temperature (operating)	$\leq 650^\circ\text{C}$
Max. hexagon temperature for short time	$\leq 700^\circ\text{C}$
Max. temperature difference between hexagon and welding seam	$\leq 330^\circ\text{C}$

- ▶ Application: lambda 0.65 to ∞
- ▶ Exhaust gas temperature: 930°C (1,030 for a short time)
- ▶ Hexagon temperature: 650°C
- ▶ Thread: M18x1.5
- ▶ Weight w/o wire: 75 g

Wire and protective sleeve temperature	$\leq 250^\circ\text{C}$
Connector temperature	$\leq 140^\circ\text{C}$
Storage temperature range	-40 to 100°C
Max. vibration (stochastic peak level)	300 m/s^2

Technical Specifications

Mechanical Data

Weight w/o wire	75 g
Thread	M18x1.5
Wrench size	22 mm
Tightening torque	40 to 60 Nm

Electrical Data

Power supply H+ nominal	7.5 V
System supply voltage	10.8 V to 16.5 V
Heater power steady state	8.7 W
Heater control frequency	≥ 100 Hz
Nominal resistance of Nernst cell	300 Ohm
Max current load for Nernst cell	$\leq 80\ \mu\text{A}$
Switch-on time	≤ 5 s

Characteristic

Signal output	I_p meas
Accuracy at lambda 0.8	$-0.652 \pm 0.032\text{ mA}$
Accuracy at lambda 1	$-0.018 \pm 0.008\text{ mA}$
Accuracy at lambda 1.7	$0.515 \pm 0.022\text{ mA}$

I_p [mA]	lambda	U_A [V], v=17	U_A [V], v=8
-1,38000	0,650	0,048	0,817
-1.11000	0.700	0.332	0.950
-0.88000	0.750	0.574	1.064
-0.65000	0.800	0.816	1.178
-0.47500	0.850	1.000	1.265
-0.37000	0.880	1.111	1.317
-0.30000	0.900	1.184	1.351
-0.16000	0.950	1.332	1.421
-0.07600	0.980	1.420	1.462
-0.04800	0.990	1.449	1.476
-0.02000	1.000	1.479	1.490
0.01167	1.030	1.512	1.506
0.03278	1.050	1.534	1.516
0.06444	1.080	1.568	1.532
0.08556	1.100	1.590	1.542
0.17000	1.180	1.679	1.584
0.23080	1.260	1.743	1.614
0.36000	1.430	1.879	1.678
0.40148	1.500	1.922	1.699
0.52000	1.700	2.047	1.758
0.54740	1.780	2.076	1.771
0.77000	2.430	2.310	1.881
1.40000	5.000	2.973	2.193

Please note: U_A is not an output signal of the lambda sensor, but the output of the evaluation circuit. Only I_p correlates with the oxygen content of the exhaust gas. Amplification factor $v=17$ is typically used for lean applications ($\lambda > 1$), amplification factor $v=8$ is typically used for rich applications ($\lambda < 1$).

Heater Strategy

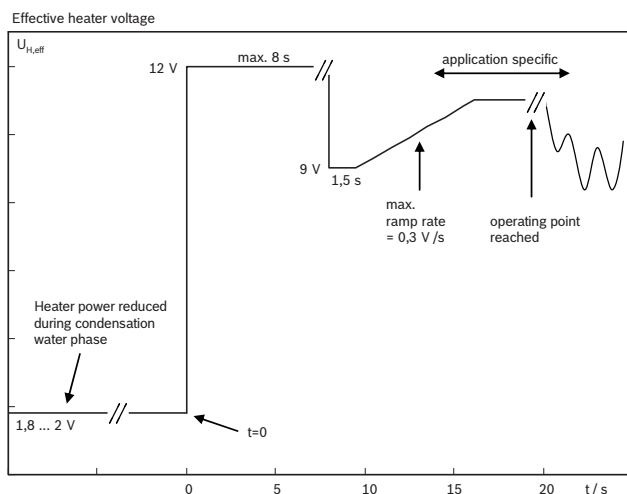

Pressure Compensation

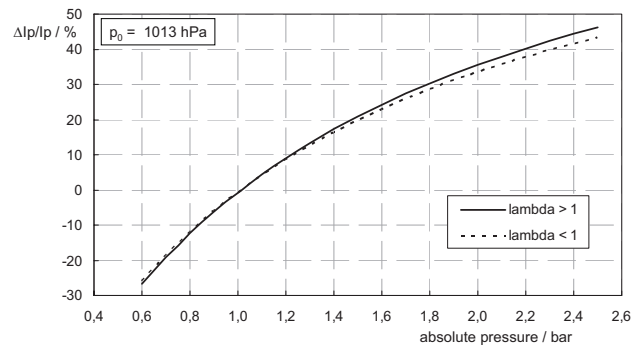

Connectors and Wires

LSU ADV with automotive connector

Connector	1 928 404 669 (Series production type, not available from Bosch Motorsport)
Mating connector	F02U.B00.725-01
Pin 1	IP/APE
Pin 2	VM/IPN
Pin 3	Uh-/H-
Pin 4	Uh+ / H+
Pin 5	nc
Pin 6	UN/RE
Wire length L	95.0 cm
Please specify the required wire length with your order.	
Sleeve	fiber glass / silicone coated
Various motorsport and automotive connectors are available on request.	

Installation Notes

This lambda sensor operates only in combination with a special evaluation unit used in lambda control unit LT4 ADV. You'll find this unit and more on our homepage at Accessories/Expansion Modules.

The lambda sensor should be installed at a point which permits the measurement of a representative exhaust-gas mixture, which does not exceed the maximum permissible temperature.

Install at a point where the gas is as hot as possible.

Observe the maximum permissible temperature.

As far as possible install the sensor vertically (wire upwards).

The sensor is not to be fitted near to the exhaust pipe outlet, so that the influence of the outside air can be ruled out.

The exhaust-gas passage opposite the sensor must be free of leaks in order to avoid the effects of leak-air.

Protect the sensor against condensation water.

The sensor is not to be painted, nor is wax to be applied or any other forms of treatment. Use only the recommended grease for lubricating the thread.

Please find further application hints in the offer drawing at our homepage.

Safety Note

The sensor is not intended to be used for safety related applications without appropriate measures for signal validation in the application system.

Legal Restrictions

Generally blocked are direct and indirect business involving high risk destinations, including Russia, Belarus, Cuba, Iran, North Korea, Syria, Libya, Afgh-

anistan, and certain non-governmental controlled Ukrainian regions. This list may change as geopolitics evolve.

Ordering Information

Lambda Sensor LSU ADV

Automotive connector, wire length 95 cm
Order number **0258.027.010**

Lambda Sensor LSU ADV

Motorsport connector, wire length customer specific (max. 90 cm)
Order number **F02U.V01.861-01**

Dimensions

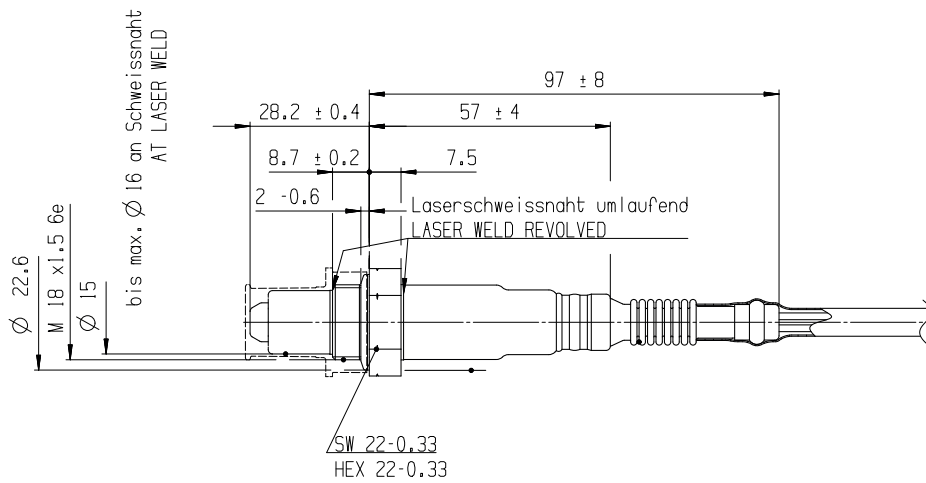

Mounting recommendation

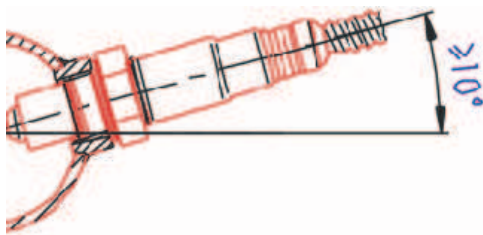

Recommended design of the mating thread in the exhaust pipe

*: T Hexagon > 600°C or
T Gas > 930°C

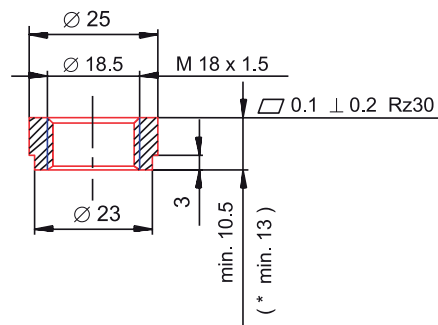

Represented by:

Europe:
Bosch Engineering GmbH
Motorsport
Robert-Bosch-Allee 1
74232 Abstatt
Germany
motorsport@bosch.com
www.bosch-motorsport.de

North America:
Bosch Engineering North America
Motorsport
38000 Hills Tech Drive
Farmington Hills, MI 48331-3417
United States of America
motorsport@bosch.com
www.bosch-motorsport.com

Asia-Pacific:
Bosch Engineering Japan K.K.
Motorsports Department
1-9-32 Nakagawachuo, Tsuzuki-ku
Yokohama-shi
Kanagawa, 224-8601
Japan
motorsport@jp.bosch.com
www.bosch-motorsport.jp

Australia, New Zealand and South Africa:
Robert Bosch Pty. Ltd
Motorsport
1555 Centre Road
Clayton, Victoria, 3168
Australia
motor.sport@au.bosch.com
www.bosch-motorsport.com.au