

Speed Sensor Hall-Effect Mini-HA-P sealed



- ▶ Max. frequency: ≤ 10 kHz
- ▶ Air gap: 0.2 to 1.5 mm
- ▶ Bore diameter: 16 mm
- ▶ Max. vibration: $1,200 \text{ m/s}^2$ at 10 Hz to 2 kHz
- ▶ Weight w/o wire: 20 g

This sensor is designed for incremental measurement of rotational speed (e.g. camshaft, crankshaft and wheelspeed).

Due to the rotation of a ferromagnetic target wheel in front of the Mini-HA-P sealed, the magnetic field is modulated at the place of the Hall probe. A Hall-effect sensor element with integrated signal conditioning circuit detects this change and generates a digital output signal.

The main feature and benefit of this sensor is the combination of a high quality production part and a robust design with a very small housing.

Application

Application	Speed
Max. frequency	≤ 10 kHz
Target wheel air gap	0.2 to 1.5 mm
Temperature range	-40 to 150°C
Output circuit	Open collector for 1 kOhm
Output type	Active low
External magnetic fields	≤ 0.3 mT
Max. vibration	$1,200 \text{ m/s}^2$ at 10 Hz to 2 kHz

Technical Specifications

Variations

Connector	ASL606-05PC-HE	Without connector
Mating connector	ASL006-05SC-HE F02U.000.228-01	-
Pin 1	U_s	U_s (red)
Pin 2	Gnd	Sig (green)
Pin 3	Sig	Gnd (black)

Pin 4	Nc	-
Pin 5	Nc	-
Wire length L	10 - 27 cm	27 cm

Mechanical Data

Weight w/o wire	19.2 g
Mounting	With screw 1 x M6
Bore diameter	16 mm
Installation depth L2	12 mm
Tightening torque	8 Nm

Electrical Data

Power supply	5 to 18 V
Current IS	10 mA

Characteristic

Accuracy repeatability of the falling edge of tooth	$< 3\%$ (≤ 6 kHz)
	$< 5\%$ (≤ 10 kHz)
Signal output	0.4 V to $< U_s$

Environment

Target wheel diameter D	162.34 mm
Thickness t	12.5 mm
Width of teeth b1	3.8 mm
Width of gap b2	4.7 mm
Width of sync. gap b3	20.79 mm
Depth of teeth h	3.4 mm
Number of teeth	60-2

Connectors and Wires

Connector	Please see Variations
Sleeve	HT wire $\varnothing 5.2$ mm

Wire size	AWG 20
Wire length L	Please see Variations
Various motorsport and automotive connectors are available on request.	
Please specify the required wire length with your order.	

Installation Notes

- The Mini-HA-P sealed can be connected directly to most control units and data logging systems.
- Please avoid abrupt temperature changes.
- For mounting please use only the integrated plug.
- If a wheel with different dimensions is used (see Environment), the technical function has to be tested individually.
- Please ensure that the environmental conditions do not exceed the sensor specifications.
- Please find further application hints in the offer drawing at our homepage.

Safety Note

The sensor is not intended to be used for safety related applications without appropriate measures for signal validation in the application system.

Legal Restrictions

Due to embargo restrictions, sale of this product in Russia, Belarus, Iran, Syria, and North Korea is prohibited.

Ordering Information

Speed Sensor Hall-Effect Mini HA-P sealed
 Connector ASL606-05PC-HE
 Order number **F02U.V00.500-01**

Speed Sensor Hall-Effect Mini HA-P sealed
 Without connector
 Order number **F02U.V00.570-01**

Dimensions

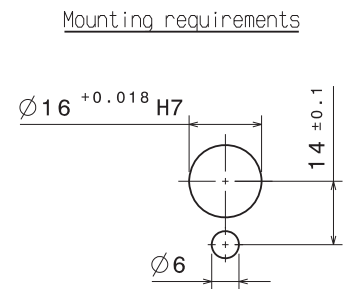
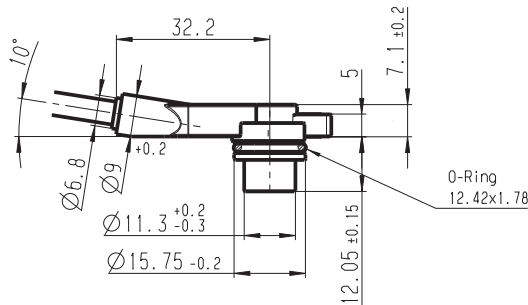
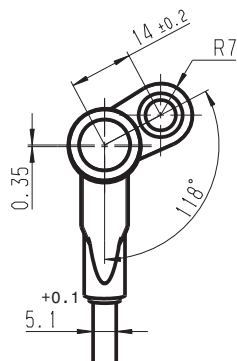

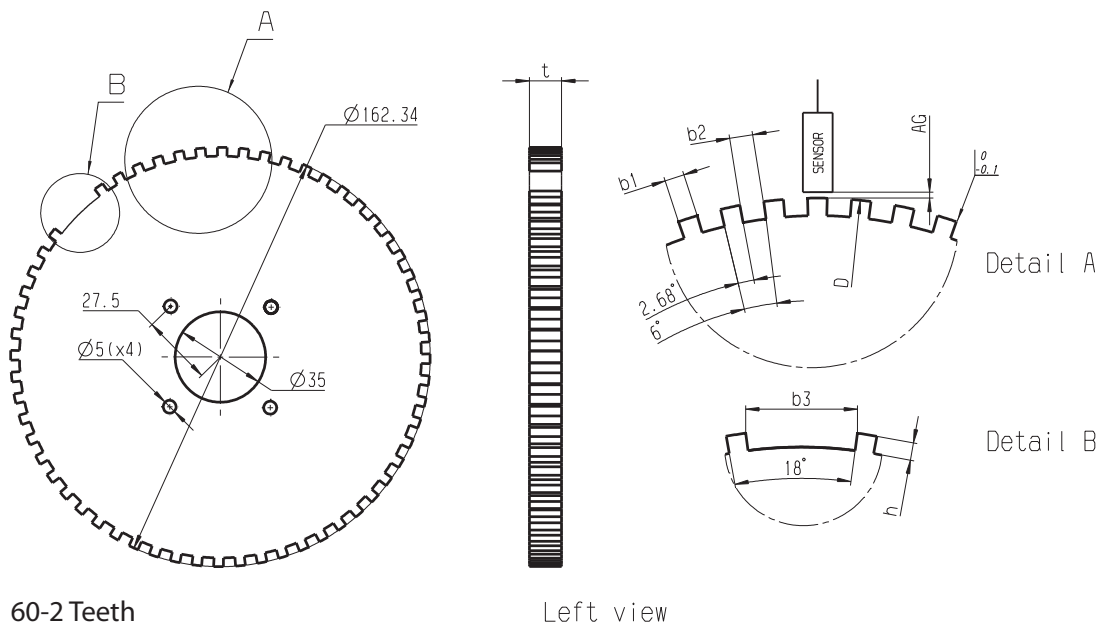

Represented by:

Europe:
 Bosch Engineering GmbH
 Motorsport
 Robert-Bosch-Allee 1
 74232 Abstatt
 Germany
 Tel.: +49 7062 911 9101
 Fax: +49 7062 911 79104
 motorsport@bosch.com
 www.bosch-motorsport.de

North America:
 Bosch Engineering North America
 Motorsport
 38000 Hills Tech Drive
 Farmington Hills, MI 48331-3417
 United States of America
 Tel.: +1 248 876 2977
 Fax: +1 248 876 7373
 motorsport@bosch.com
 www.bosch-motorsport.com

Asia-Pacific:
 Bosch Engineering Japan K.K.
 Motorsport
 18F Queen's Tower C, 2-3-5 Minato
 Mirai Nishi-ku, Yokohama-shi
 Kanagawa 220-6218
 Japan
 Tel.: +81 45 650 5610
 Fax: +81 45 650 5611
 www.bosch-motorsport.jp

Australia, New Zealand and South Africa:
 Robert Bosch Pty. Ltd
 Motorsport
 1555 Centre Road
 Clayton, Victoria, 3168
 Australia
 Tel.: +61 (3) 9541 3901
 motor.sport@au.bosch.com