

Beim Bau schon in diese Richtung legen, evtl. auch Formteil leicht biegen, Abgang kurz und flexibel ausführen !!

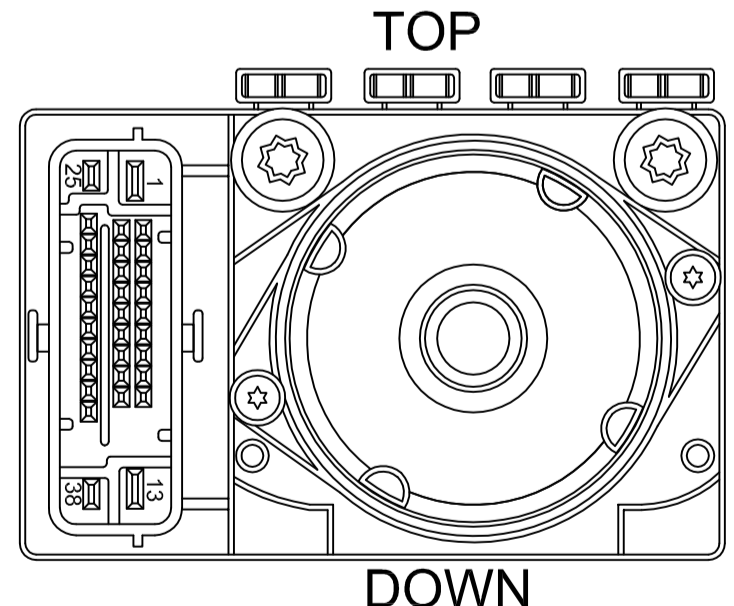
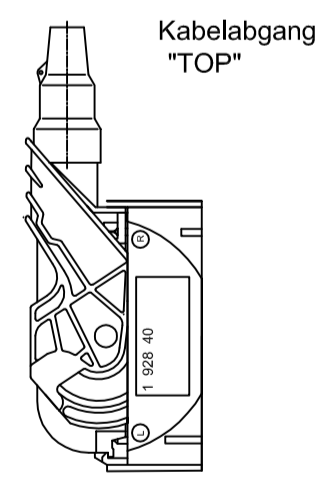
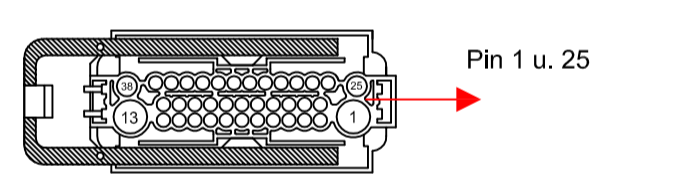
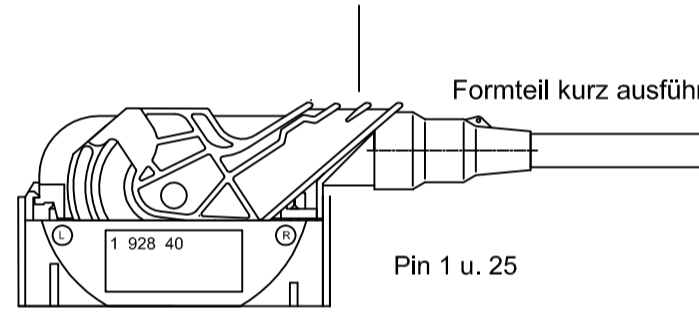
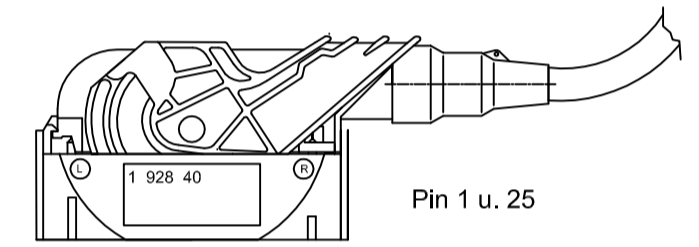

- shorten tail length of all boots 202D9XX-25 by half
- all transitions bonded
- all boots bonded at front and rear side or use -225 (w/ glue)
- all wires twisted
- all legs labeled
- all dimensions are metric
- boots with terminals must be sealed
- complete loom in DR-25
- fully populate all connectors with pins and sockets
- all unterminated screens to be folded back and sealed

F02U.V02.753-01	F02U.S02.752-01	ABS M5 harness Porsche 991 CUP Gen1
Bestell-Nummer order number	Entwurfszeichnung schematic	Benennung part name

In all cases of doubt, the text in the original language is binding. In allen Zweifelfällen ist der Text in der Ausgangssprache verbindlich.		Original language: Ausgangssprache:	de
01 Anlage	20180613	SrM	BEG/MSD-NE4
YYMMDD	YYYYMMDD	Drawn/Gez.	Checked/Gepr.
Relass./Freig.	BWN	Revis./Änder./Änd.	Revis./Änder./Änd.
Mat.Stoff		From/As	
Lang./Spr.	en/de	Night/Gen.	
Scale/Maßstab		BOSCH	
MNR	NZ580-1	CAT	Rep./for
ABS M5 Porsche 991 Cup Front		F02U.V02.753-01	
DP/ID	Ind.	Format	A1

This drawing is the exclusive property of Robert Bosch GmbH.
 This drawing and its content may not be reproduced or used in any form without the prior written permission of Robert Bosch GmbH.