

Checkliste

- MaterialNr gelabelt
- Alle Labels ok
- Eintauchmaß richtig
- Kabelfarben/Querschnitt richtig
- Verklebung sauber
- Kabelabgang richtig ausgeführt
- Kabellänge richtig
- Kontakt-Ausdrückprüfung erl.
- Kontaktspannung ok
- Gewinde gesichert
- Programmierung erfolgt
- Ggfs. endoskopiert
- Ggfs. geröntgt
- Protokoll/Doku beiliegend/abgelegt
- Endprüfung erfolgt
- 4 Augen Prinzip erfüllt
- Abdeckkappen/Transportsicherung/Verpackung vorhanden

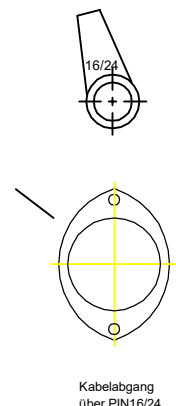

Kabelabgang über PIN16/24

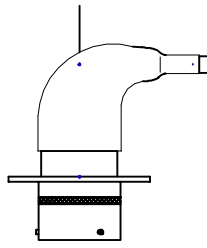

Intersection ABS Front
AS 0-16-35-SN
222K142-25
SP/ABS FRONT

ACHTUNG
2x Gewinde M4 in Flansch schneiden

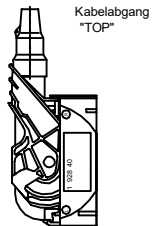

Wire Exit: top straight
F02U.B00.238-01

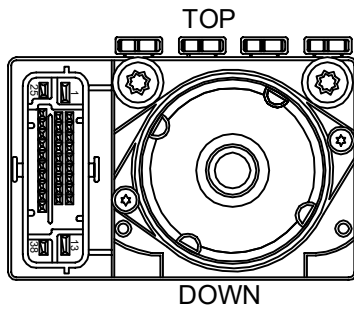

DOWN

- shorten tail length of all boots 202D9XX-25 by half
- all transitions bonded
- all boots bonded at front and rear side or use -225 (w/ glue)
- all wires twisted
- all legs labeled
- all dimensions are metric
- boots with terminals must be sealed
- complete loom in DR-25
- fully populate all connectors with pins and sockets
- all unterminated screens to be folded back and sealed

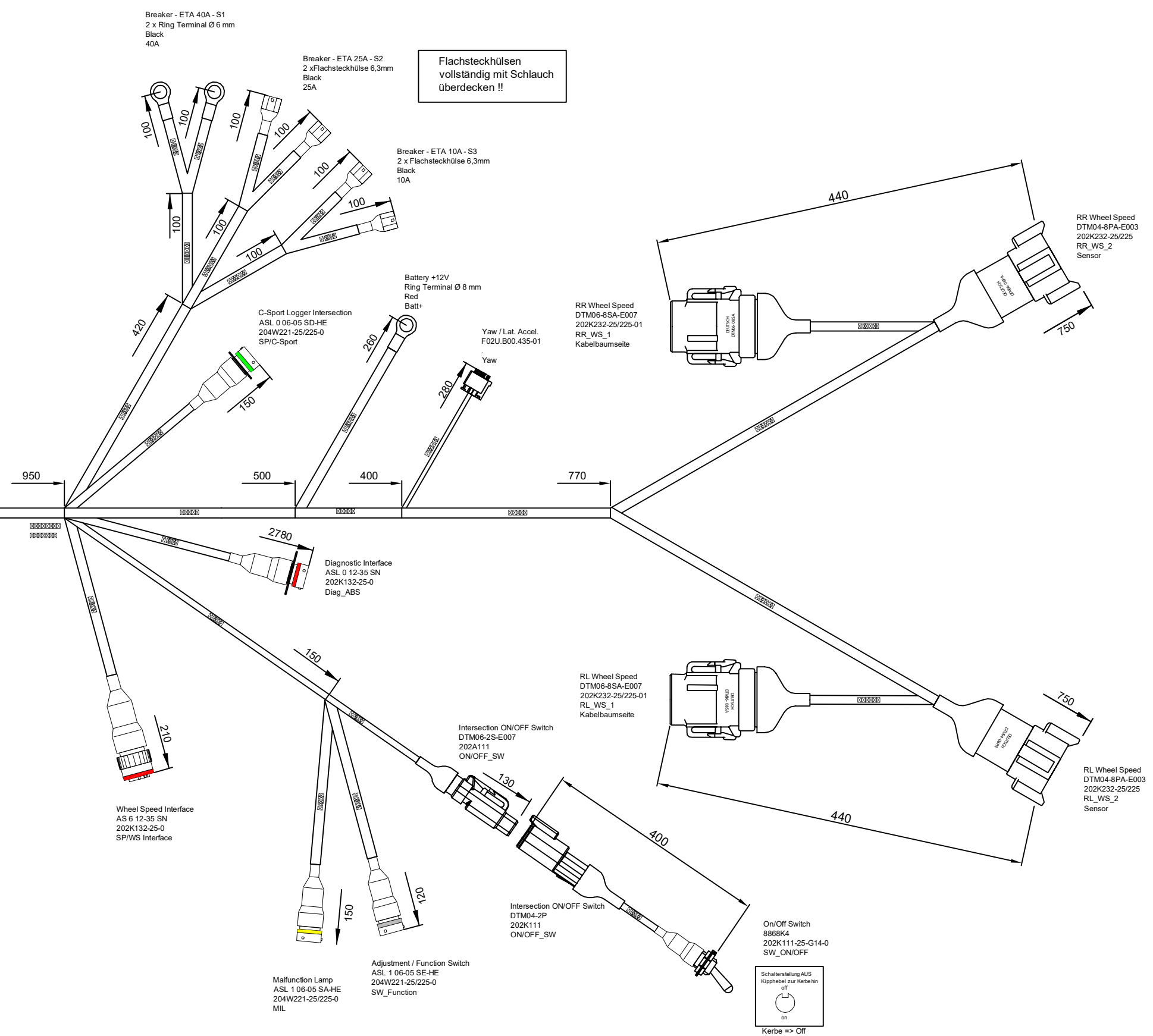

Flachsteckhülsen
vollständig mit Schlauch
überdecken !!



On/Off Switch
886BK4
202K111-25-G14-0
SW_ON/OFF

Schalterstellung AUS
Kipphel zur Kerbe hin
off
on
Kerbe => Off

In all cases of doubt, the text in the original language is binding. In allen Zweifelsfällen ist der Text in der Ausgangssprache verbindlich.		Original language: Ausgangssprache	de			
03	Länge Diag	20180914	SRM	BEG/MSD-NE4	J + Austritt Diag	
02	Länge Diag	20180612	SRM	BEG/MSD-NE4		
01	Anlage	20180320	SRM	BEG/EMS3		
Ind.	Change/Verf.	YYYYMMDD	Drawn/Gez.	Checked/Gepr.	Released/Verf. Abg.	Adm. Info./Zus. Inf.
Treatment / Behandlung		Material / Material		Process / Prozess		Scale / Maßstab
Lang./Spr. / Sprache	Druck/Verf. / Druck/Verf.	Druck/Verf. / Druck/Verf.	Druck/Verf. / Druck/Verf.	Druck/Verf. / Druck/Verf.	Druck/Verf. / Druck/Verf.	Druck/Verf. / Druck/Verf.
BOSCH		ABS Porsche 991 CUP Gen.2 Heck		F02U.V02.755-03		Sheet / Blatt
N2580-1		CAT		A1		

Bestell-Nummer order number	F02U.V02.755-03	Entwurfszeichnung schematic	F02U.S02.754-01	Benennung part name	ABS M5 harness Porsche 991 CUP Gen.2
--------------------------------	-----------------	--------------------------------	-----------------	------------------------	---