

Vehicle Control Unit MS 50.4P CAN-FD incl. CCA and Multi-CCA



- ▶ 866 MHz Dual Core Processor exclusively for vehicle control functionality (MATLAB based)
- ▶ Identical, dedicated 866 MHz Dual Core Processor exclusively for logging purposes
- ▶ High Speed Logging 200 kHz of 6 analog inputs (optional)
- ▶ Up to 8 CAN buses, CAN 3 to CAN 8 are CAN-FD compatible

The VCU MS 50.4P CAN-FD is a highly powerful processing / logging unit for race applications. Based on our broad base of platform function, we support you with customized VCU functions for a tailor-made solution. In addition, you can quickly develop your individual customer software based on MATLAB/Simulink to significantly speed up algorithm development (automatic code and documentation generation) – including extensive simulation capabilities.

Application

Processor for customer code	866 MHz Dual Core
Processor for logger	866 MHz Dual Core
Configurable math channels	
User configurable CAN in/out messages	
Online data compression	
Internal logger	
• 1,500 channels	
• FULL_LOG_1 (4 GB memory on Partition 1) enabled	
• PERF_LOG_1 (16 GB memory on Partition 1) optional	
• FULL_LOG_2 (4 GB memory on Partition 2) enabled	
• High Speed Logging Package (Sampling rate 5 µs) optional	
• DATA_USB (Data copy to USB flash drive) enabled	
Logging rates	
• Usage of all features: 800 kB/s	
• Primary logging use case: >1,500 kB/s	
• Logging data download rate: up to 7.5 MB/s	
LTE Ethernet telemetry support	
RS232 interface for GPS	
Customer Code Area CCA	

Provides the option to run customer developed software code on Bosch device

Multi CCA

Enables the use of an extra core to utilize more computing power in the device for running a second customer model

Technical Specifications

Mechanical Data

Size	166 x 121 x 41 mm
Weight	≤ 660 g
Protection classification	IP67
3 motorsport connectors, 198 pins in total	
Max. vibration	Vibration profile 1
Operating temperature internal	0 to 85°C

Operation outside the temperature limits can be tested on request during the manufacturing tests.

Electrical Data

Supply voltage	5 to 18 V
----------------	-----------

Inputs

20 Analog channels 0 to 5 V, 0.5 % precision between 0.2 and 4.8 V, switchable pull-up

8 Digital PWM inputs $f_{max}=30$ kHz Hall-type speed measurement possible, Switchable pullup 2.15 kOhm, (required for Hall), Tooth count differential*

4 Digital PWM inputs $f_{max}=30$ kHz Hall- and DF11 type speed measurement possible, Fixed pullup 2.15 kOhm (required for Hall), Tooth count differential*

4 universal Thermocouple
1 Bosch Laptrigger
1 TimeSync master and slave (specific to Bosch measurement system)
Internal measurements:
1 x ambient pressure
1 x ECU temperature
20 x supply voltage
20 x supply current
1 x battery voltage (external VCU supply)
1 x external VCU supply current
4 x HS output current
1 x 3-axis acceleration plus roll/pitch/yaw rate

Outputs

2* x PWM High side; 7.5 A each, PWM, 50 Hz
4* x PWM Low side; 2.2 A each, PWM, 10 kHz
*can be enhanced by Upgrade I/O Package

Sensor Supplies and Screens

5* x 12 V, 400 mA each
5* x Switchable 5 V/12 V, 400 mA each
4 A max overall current on all 12 V
2 A max overall current on all 5 V
12 V ± 1 % precision on the pin
5 V ± 0.1 % precision on the pin
20 x Sensor ground
*can be enhanced by Upgrade I/O Package

Adaptation and Documentation

Function documentation	Automatically created during code generation
MatLab code generation	Support for customer own MatLab function development

Software Tools (free download)

Data Analysis tool WinDarab 7	
System Configuration tool RaceCon	Logger configuration, calibration, and online measurement

Connectors

Connector LIFE (red) AS018-35PN	Mating connector AS618-35SN (not included)
Connector SENS-A (yellow) AS018-35PA	Mating connector AS618-35SA (not included)
Connector SENS-B (blue) AS018-35PB	Mating connector AS618-35SB (not included)

Communication

3 Ethernet 100 Mbit
4 CAN (+4 with Upgrade I/O Package), CAN 3 to CAN 8 are CAN-FD compatible
1 LIN

1 USB
1 RS232 interface for GPS or Telemetry, switchable depending on SW version
1 Time sync synchronization Ethernet

Installation Notes

Maintenance Interval: 220 h or a maximum of two years
 Please remember that the mating connectors and the programming interface MSA-Box II are not included and must be ordered separately.

Legal Restrictions

Generally blocked are direct and indirect business involving high risk destinations, including Russia, Belarus, Cuba, Iran, North Korea, Syria, Libya, Afghanistan, and certain non-governmental controlled Ukrainian regions. This list may change as geopolitics evolve.

Upgrades

I/O Package

Communication

4 CAN

Inputs

4 Analog channels
 0 to 5 V,
 0.5 % precision between 0.2 and 4.8 V, switchable pull-up

4 Digital PWM inputs
 f_{max}=30 kHz
 Hall-type speed measurement possible,
 Fixed pullup 2.15 kOhm (required for Hall),
 Tooth count differential**

4 LVDT, 5 pin configuration,
 excitation frequency 1 to 20 kHz,
 excitation voltage 0 to 5 V (rms)

Outputs

4 "TTL" Digital output, 10 kHz, PWM, 25 mA each

2 PWM High side; 7.5 A each, PWM, 50 Hz

4 PWM Low side; 2.2 A each, PWM, 10 kHz

Power Supplies

5 x12 V, 400 mA each

5 switchable 5 V/12 V, 400 mA each

** The tooth count differential between any two of the PWM inputs is available two measure e.g. shaft torsion.

PERF_LOG_1

Increase logging Partition 1 from 4 GB to 16 GB memory

High Speed Logging Package

6 ANA	0 to 5 V, 200 kHz logging rate
-------	--------------------------------

CCP/XCP_MASTER

Enables CCP/XCP master functionality to request data from foreign devices via CAN/CCP protocol, XCP over Ethernet (UDP) or XCP via CAN.
(ASAP2 file from ECU manufacturer required)

Ordering Information

Vehicle Control Unit MS 50.4P CAN-FD incl. CCA and Multi-CCA

Order number **F02U.V03.515-01**

Rugged USB flash drive

Order number **F02U.V03.534-01**

Connector for USB flash drive on car loom side

Order number **F02U.002.996-01**

Adapter cable to PC USB-Port

Order number **F02U.V01.343-01**

Breakout Box BOB 66-pole

Connector code: blue

Order number **F02U.V02.295-01**

Breakout Box BOB 66-pole

Connector code: yellow

Order number **F02U.V02.298-01**

Breakout Box BOB MS 7

Connector code: red

Order number **F02U.V02.293-01**

Software Options

I/O Package

Order number **F02U.V02.777-01**

PERF_LOG_1

Order number **F02U.V03.054-01**

High Speed Logging Package

Order number **F02U.V02.779-01**

CCP/XCP_MASTER

Order number **F02U.V02.213-01**

Real Time Ethernet

Order number **F02U.V02.782-01**

Accessories

Opening tool for shellsize 18

Order number **F02U.V01.394-01**

Dimensions

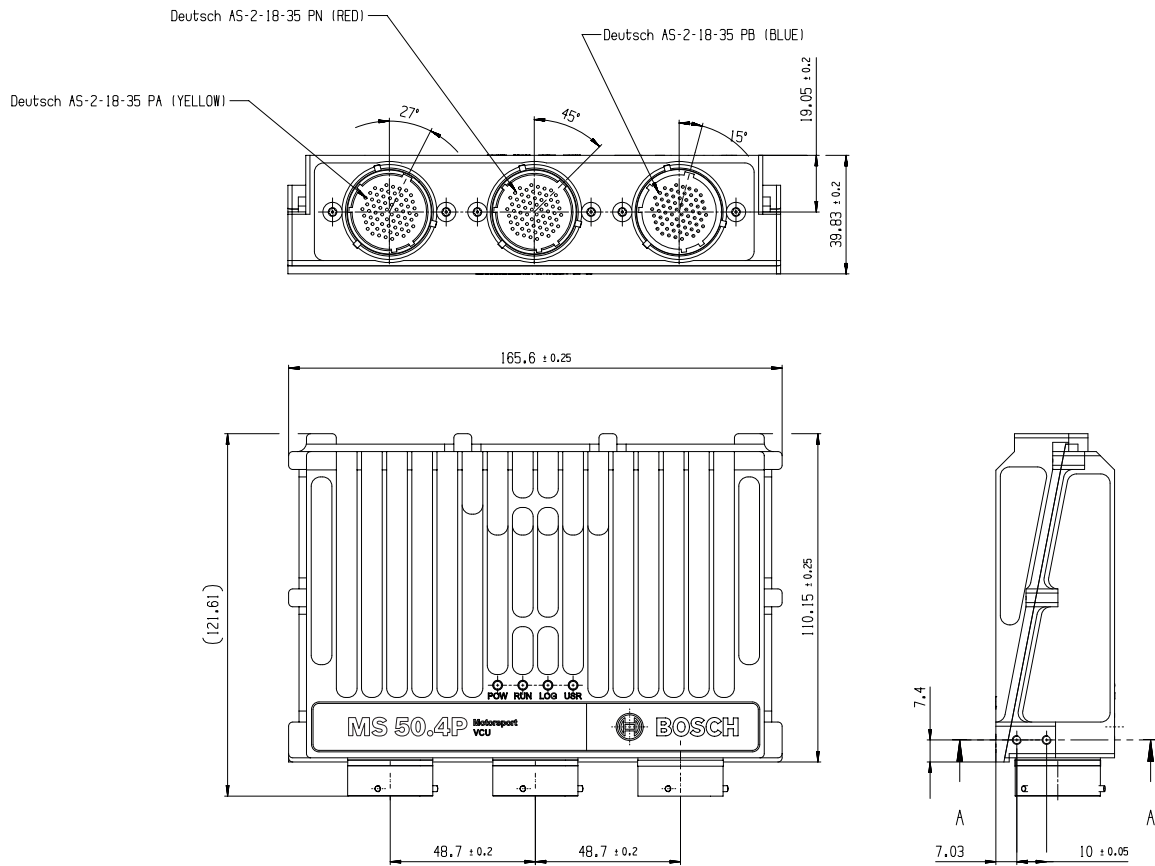

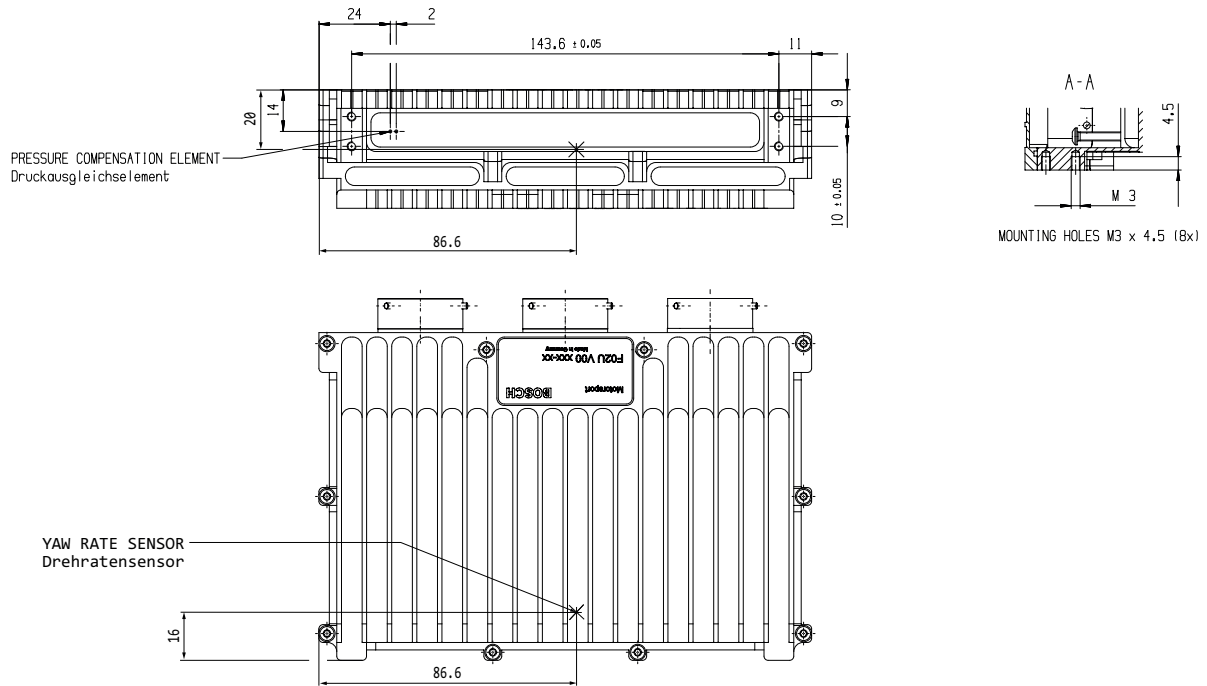

Represented by:

Europe:
 Bosch Engineering GmbH
 Motorsport
 Robert-Bosch-Allee 1
 74232 Abstatt
 Germany
 motorsport@bosch.com
 www.bosch-motorsport.de

North America:
 Bosch Engineering North America
 Motorsport
 38000 Hills Tech Drive
 Farmington Hills, MI 48331-3417
 United States of America
 motorsport@bosch.com
 www.bosch-motorsport.com

Asia-Pacific:
 Bosch Engineering Japan K.K.
 Motorsports Department
 1-9-32 Nakagawachuo, Tsuzuki-ku
 Yokohama-shi
 Kanagawa, 224-8601
 Japan
 motorsport@jp.bosch.com
 www.bosch-motorsport.jp

Australia, New Zealand and South Africa:
 Robert Bosch Pty. Ltd
 Motorsport
 1555 Centre Road
 Clayton, Victoria, 3168
 Australia
 motor.sport@au.bosch.com
 www.bosch-motorsport.com.au