

Ignition Coil C90i-pro



- ▶ Max. 40 kV
- ▶ Min. 90 mJ
- ▶ Max. 5.0 kV/μs
- ▶ Max. 15,000 1/min
- ▶ Developed for Turbo-GDI engines

This single fire coil was developed for the use e.g. in GDI (turbocharged) high performance engines. It is designed for direct cylinder head mounting.

The main benefits of this high performance coil are its high energy capability and a very good provided high voltage.

Application

Spark energy	≥ 90 mJ
Primary current	≤ 16 A
Operating temperature range outer core	0 to 160°C
Storage temperature range	-40 to 100°C
Max. vibration	≤ 480 m/s ² at 50 to 2,000 Hz

Technical Specifications

Mechanical Data

Length	168 mm
Weight w/o wire	250 g
Mounting	screw fastening

Electrical Data

Primary resistance	185 mOhm
Secondary resistance	Incapable of measurement
High voltage rise time	≤ 5.0 kV/μs
Max. high voltage at 1 MOhm 10 pF	≤ 40 kV
Spark current	≤ 160 mA
Spark duration at 1 kV 1 MOhm	≤ 1.1 ms
Noise suppression	Inductive

Suppression diode / EFU	Internal
-------------------------	----------

Characteristic

Measured with power stage	IGBT IRG4BC40S (U _{ce} =600 V)
---------------------------	---

Connectors and Wires

Connector	On request
Mating connector	On request
Pin 1	Red: U _{batt}
Pin 2	Blue: ECU ignition power stage
Pin 3	Black: Engine GND
Pin 4	White: Ionic current signal measurement preparation

Wire length	100 cm
-------------	--------

Wire size	AWG 20/22/24
-----------	--------------

For spark plugs	Ceramic diameter d = 10 mm
-----------------	----------------------------

Various motorsport and automotive connectors are available on request.

Please specify the required wire length and the length of the spark plug connector with your order

Characteristic dwell times [ms]

U _{batt}	I _{primary}					
	10A	12A	15A	16A	17A	20A
6V	3.2	4.5	7.6	9.8		
8V	1.88	2.49	3.47	3.79	4.10	
10V	1.35	1.76	2.34	2.51	2.67	3.05
12V	1.06	1.35	1.77	1.89	2.00	2.24
14V	0.87	1.11	1.43	1.52	1.60	1.79
16V	0.74	0.93	1.20	1.28	1.34	1.49

16.5V	0.71	0.90	1.15	1.23	1.29	1.43
18V	0.64	0.81	1.03	1.10	1.15	1.27

Measured values are without loom resistance. Loom resistance must be less than the primary resistance. The needed dwell time is to be verified through current measurement

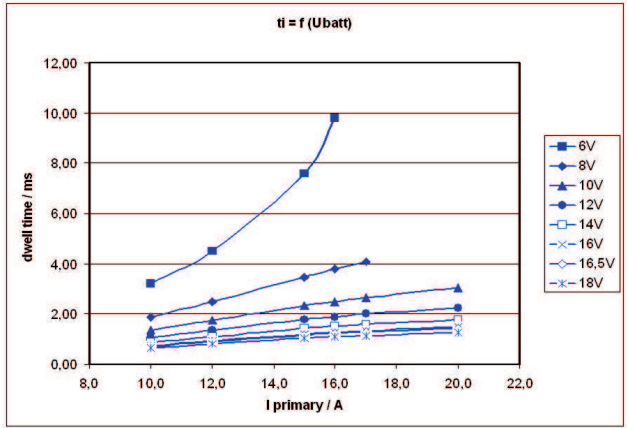

Dwell time
Spark energy and provided high voltage

I prim.	Spark energy	-duration	-current	Hi voltage
10 A	41.4 mJ	0.74 ms	100 mA	31.6 kV
12 A	59.5 mJ	0.882 ms	122 mA	37.4 kV
15 A	84.4 mJ	1.034 ms	148 mA	45.7 kV
16 A	92.6 mJ	1.07 ms	158 mA	46 kV
17 A	100 mJ	1.09 ms	165 mA	46 kV
20 A	115 mJ	1.16 ms	190 mA	46 kV

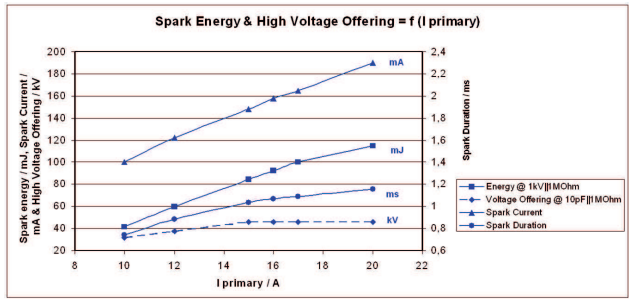

Spark energy

Installation Notes

During mounting of the spark plug please pay attention that full clamping and proper contacts are made to ensure safe connection between coil and spark plug.

This coil is only for use with engine control units having an integrated ignition power stage, e.g. IGBT IRG4BC40S or BIP.

For technical reasons the values of the coils may vary.

Please regard the specified limit values (see "Electrical Data").

Usage above Iprim = 16 A or 40 kV may reduce the lifetime.

Please find further application hints in the offer drawing at our homepage.

Design Note

We strongly recommend the design of the spark plug shaft has to ensure that there are no sharp edges in the shaft geometry due to design or machining. Only in compliance with this recommendation, a proper function can be ensured.

Ordering Information

Single Fire Coil C90i-pro
Order number **F037.000.996**

Dimensions

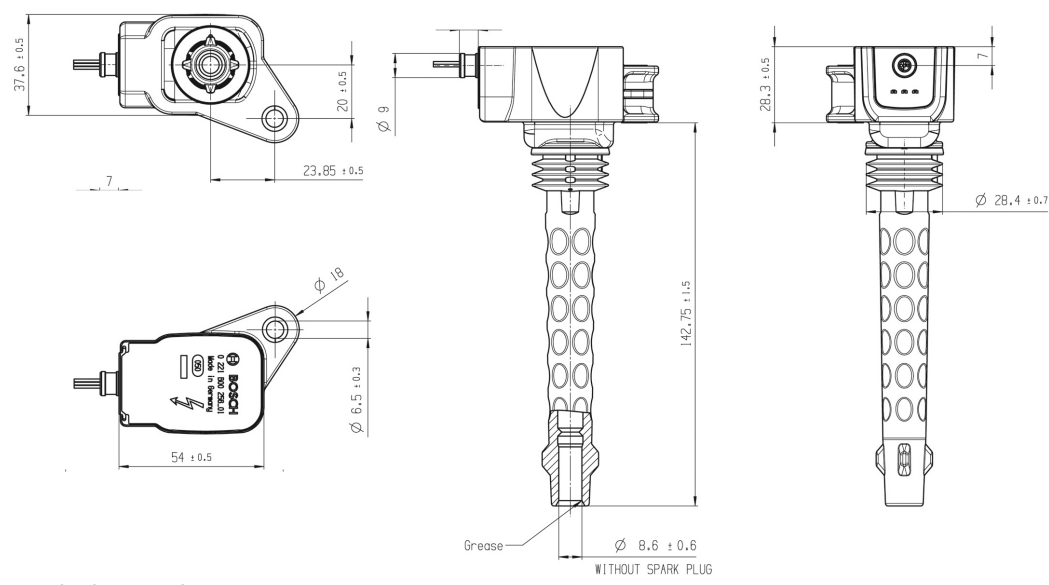

See Offer Drawing for further information

Represented by:

Europe:

Bosch Engineering GmbH
Motorsport
Robert-Bosch-Allee 1
74232 Abstatt
Germany
motorsport@bosch.com
www.bosch-motorsport.de

North America:

Bosch Engineering North America
Motorsport
38000 Hills Tech Drive
Farmington Hills, MI 48331-3417
United States of America
motorsport@bosch.com
www.bosch-motorsport.com

Asia-Pacific:

Bosch Engineering Japan K.K.
Motorsports Department
1-9-32 Nakagawachuo, Tsuzuki-ku
Yokohama-shi
Kanagawa, 224-8601
Japan
motorsport@jp.bosch.com
www.bosch-motorsport.jp

Australia, New Zealand and South

Africa:
Robert Bosch Pty. Ltd
Motorsport
1555 Centre Road
Clayton, Victoria, 3168
Australia
motor.sport@au.bosch.com
www.bosch-motorsport.com.au