

Ignition Coil P65-TWG



- ▶ Max. 33 kV
- ▶ Min. 65 mJ
- ▶ Connection for high voltage wire
- ▶ Max. 10,000 1/min (with reduced dwell time)
- ▶ Developed for GDI engines

This single fire coil is a low cost concept designed to connect a high voltage wire on the coil. The coil has an integrated transistor and requires an ECU with internal ignition drivers.

Application

Spark energy	≥ 65 mJ
Primary current	≤ 7.0 A
Operating temperature range at outer core	-40 to 140°C
Storage temperature range	-40 to 140°C
Max. vibration	≤ 250 m/s ² at 5 to 2,000 Hz

Technical Specifications

Mechanical Data

Length	83 mm
Weight	210 g
Mounting	Screw fastening

Electrical Data

Primary resistance with wire	Incapable of measurement
Secondary resistance	Incapable of measurement
High voltage rise time	≤ 1.4 kV/μs
Max. high voltage at	≤ 33 kV
Spark current	≤ 70 mA
Spark duration at 1 kV 1 MOhm	≤ 1.85 ms
Noise suppression	Inductive and 1 kOhm resistance

Integrated suppression diode / EFU	
Integrated power stage	

Characteristic

Measured with power stage	BIP 385
---------------------------	---------

Connectors and Wires

Connector primary side	Tyco 0-1488991-1
Mating connector primary side	F02U.B00.555-01
Pin 1	ECU ignition signal
Pin 2	ECU GND
Pin 3	U _{batt}
30 kV grid connector	See Accessories

Characteristic dwell times [ms]

U _{batt}	I _{primary}					
	5.0 A	5.5 A	6.0 A	6.5 A	7.0 A	7.5 A
Max. 1000 /min	10	9	8	7	6	5
6 V	10.7	11.6				
8 V	4.7	5.4	6.8	8.3	10.2	
10 V	3.1	3.55	4.25	4.87	5.6	6.3
12 V	2.32	2.66	3.12	3.51	3.94	4.36
14 V	1.86	2.1	2.45	2.75	3.07	3.36
16 V	1.55	1.77	2.03	2.26	2.51	2.73
16.5 V	1.49	1.7	1.95	2.17	2.40	2.61
18 V	1.34	1.51	1.73	1.92	2.13	2.31
20 V	1.16	1.33	1.51	1.67	1.85	2.0

24V 0.93 1.05 1.19 1.32 1.45 1.57

Measured values are without loom resistance. Loom resistance must be less than the primary resistance. The needed dwell time is to be verified through current measurement

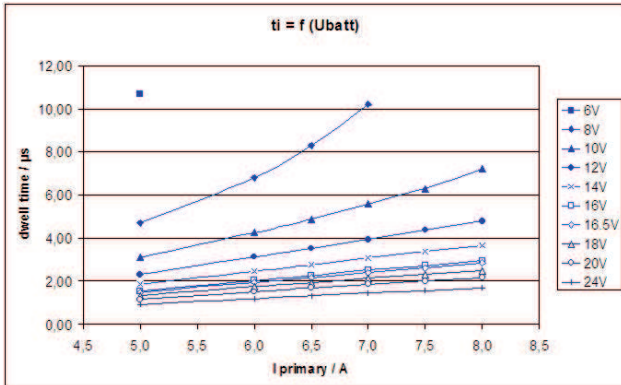

Dwell time

Spark energy and provided high voltage

I prim.	Spark energy	-duration	-current	Hi voltage
5 A	33.7 mJ	1.37 ms	50 mA	24.4 kV
5.5 A	42 mJ	1.54 ms	54 mA	27.0 kV
6 A	48.9 mJ	1.62 ms	59 mA	29.1 kV
6.5 A	55.9 mJ	1.74 ms	63 mA	31.2 kV
7 A	63.6 mJ	1.85 ms	68 mA	33.2V
7.5 A	71.9 mJ	1.92 ms	73 mA	34.7 kV

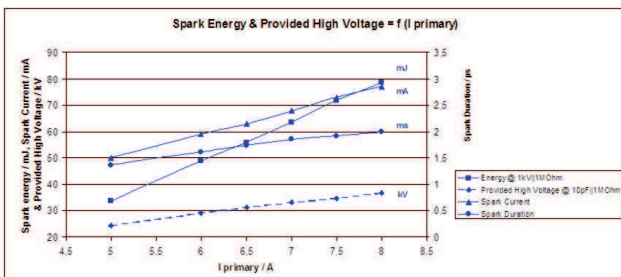

Spark Energy

Installation Notes

During mounting of the spark plug please pay attention that full clamping and proper contacts are made to ensure safe connection between coil and spark plug (high voltage wire).

The coil P65-T has an integrated transistor and requires an ECU with internal ignition drivers with 10 to 20 mA current output.

For technical reasons the values of the coils may vary.

Please regard the specified limit values.

Please find further application hints in the offer drawing at our homepage.

In case of ignition-caused malfunctions, please use screened sensor wires.

Design Note

We strongly recommend the design of the spark plug shaft has to ensure that there are no sharp edges in the shaft geometry due to design or machining. Only in compliance with this recommendation, a proper function can be ensured.

Legal Restrictions

Generally blocked are direct and indirect business involving high risk destinations, including Russia, Belarus, Cuba, Iran, North Korea, Syria, Libya, Afghanistan, and certain non-governmental controlled Ukrainian regions. This list may change as geopolitics evolve.

Ordering Information

Ignition Coil P65-TWG

Order number **F02U.V02.429-01**

Dimensions

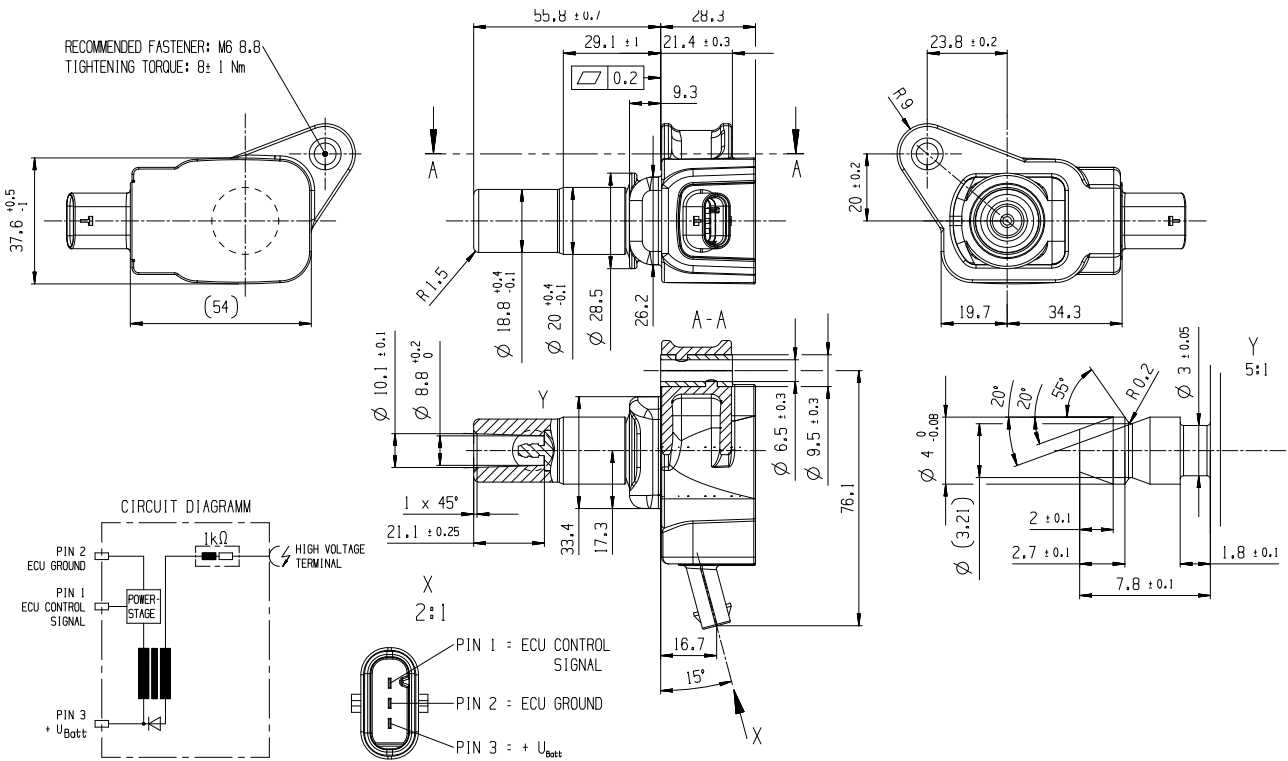

See Offer Drawing for further information

Represented by:

Europe:
Bosch Engineering GmbH
Motorsport
Robert-Bosch-Allee 1
74232 Abstatt
Germany
motorsport@bosch.com
www.bosch-motorsport.de

North America:
Bosch Engineering North America
Motorsport
38000 Hills Tech Drive
Farmington Hills, MI 48331-3417
United States of America
motorsport@bosch.com
www.bosch-motorsport.com

Asia-Pacific:
Bosch Engineering Japan K.K.
Motorsports Department
1-9-32 Nakagawachuo, Tsuzuki-ku
Yokohama-shi
Kanagawa, 224-8601
Japan
motorsport@jp.bosch.com
www.bosch-motorsport.jp

Australia, New Zealand and South Africa:
Robert Bosch Pty. Ltd
Motorsport
1555 Centre Road
Clayton, Victoria, 3168
Australia
motor.sport@au.bosch.com
www.bosch-motorsport.com.au