

Lambdatronic LT4



- ▶ Supply of up to 4 Bosch lambda sensors, type LSU 4.2, LSU 4.9 or Mini-LSU 4.9
- ▶ Integrated voltage compensation for sensor heater

The Lambdatronic LT4 provides controlled pumping current to supply up to 4 Bosch lambda sensors, type LSU 4.2, LSU 4.9 or Mini-LSU 4.9. The lambda value, the sensor temperature and diagnostics are available via CAN and analog signal.

The LSU contains a Nernst and a pump cell. The lambda in the Nernst cell is controlled to $\lambda = 1.013$ independent of the oxygen contents on the emission side, through a current through the pump cell. The current proportional output voltage of the IC is a measure of the lambda value.

The main feature and benefit of this unit is the combination of the Bosch well known lambda IC and a very compact box size with motorsport specification. Furthermore the analog signal output can be configured freely.

Application

Application	Lambda 0.75 to 10.12
Compatible Bosch sensor type	LSU 4.2, LSU 4.9, Mini-LSU 4.9
Channels	4
Heater	Internal

Technical Specifications

Mechanical Data

Weight with wire	98 g
Sealing	100 % humidity
Mounting	Velcro
Size w/o wire (w*h*t)	54 x 59 x 13 mm
Operating temp. range (housing)	-20 to 85°C

Storage temp. range	-20 to 85°C
Max. vibration	Vibration Profile 1

Electrical Data

Power supply U_s	(6.5) 10 to 14 V
Max power supply (1 min) U_s	Max. 26 V
Thermal dissipation loss	3 W at 14 V
Current I_s	5 A
Current I_s (Heating up)	26 A

Software Tool (free download)

System Configuration tool RaceCon 2.7.0.9 or later

Characteristic

Signal output 1	CAN
Signal output 2	4 x 0 to 5 V "analog"
CAN- baud rate	500 kbaud or 1 Mbaud
Signal resolution	2,5 * 10 ⁻⁴ lambda
Signal sampling rate	100 Hz
CAN refresh rate	100 Hz

Connectors and Wires

Connector	AS614-35PN
Connector loom	F02U.000.365-01
AS114-35SN	
Sleeve	Viton
Wire size	26
Wire length L	20 cm

Pin Assignment

Pin	Function
1	+ 12 V (Battery +)

2	+ 12 V (Battery +)
3	Ground (Battery -)
4	Ground (Battery -)
5	K-Line diagnostic connection
6	CAN1 + (high)
7	CAN1 - (low)
8	Analog out 1
9	Analog out 2
10	Analog out 3
11	Analog out 4
12	Reference GND for analog out
13	Shield
14	Pump current LSU 1 IP1
15	Virtual GND LSU 1 VM1
16	Heater PWM LSU 1 Uh-1
17	Heater (Batt +) LSU 1 Uh+1
18	Setup current LSU 1 IA1
19	Nernst voltage LSU 1 UN1
20	Pump current LSU 2 IP2
21	Virtual GND LSU 2 VM2
22	Heater PWM LSU 2 Uh-2
23	Heater (Batt. +) LSU 2 Uh+2
24	Setup current LSU 2 IA2
25	Nernst voltage LSU 2 UN2
26	Pump current LSU 3 IP3
27	Virtual GND LSU 3 VM3
28	Heater PWM LSU 3 Uh-3
29	Heater (Batt +) LSU 3 Uh+3
30	Setup current LSU 3 IA3
31	Nernst voltage LSU 3 UN3
32	Pump current LSU 4 IP4
33	Virtual GND LSU 4 VM4
34	Heater PWM LSU 4 Uh-4
35	Heater (Batt. +) LSU 4 Uh+4
36	Setup current LSU 4 IA4
37	Nernst voltage LSU 4 UN4

Communication

Communication link	K-Line / CAN
--------------------	--------------

Installation Notes

Typical lifetime: max. 220 h / 2 years

For application with severe conditions and/or high volume, please contact your Bosch Motorsport counterpart in order to define the most appropriate validation program

The LT4 is designed to supply 4 Bosch lambda sensors, type LSU 4.2, LSU 4.9 or Mini-LSU 4.9

The LT4 is featured with voltage compensation for the heating profile

The unit can be connected to any CAN system (500 kbaud or 1 Mbaud) and analog measuring device.

To avoid signal errors, a cable length of maximum 1.5 m between sensor and box is recommended.

The unit is secure from miss-pinning.

The reference ground (GND_REF) has to be connected either to the measuring device or to the system ground.

A ground offset of 2 V (max.) between GND and GND_REF has not to be exceeded.

See the LT4 function sheet for software documentation (e.g. CAN protocol).

Please find further application hints in the offer drawing at our homepage.

Legal Restrictions

Generally blocked are direct and indirect business involving high risk destinations, including Russia, Belarus, Cuba, Iran, North Korea, Syria, Libya, Afghanistan, and certain non-governmental controlled Ukrainian regions. This list may change as geopolitics evolve.

Ordering Information

Lambdatronic LT4

Order number **F01T.A20.070-09**

Dimensions

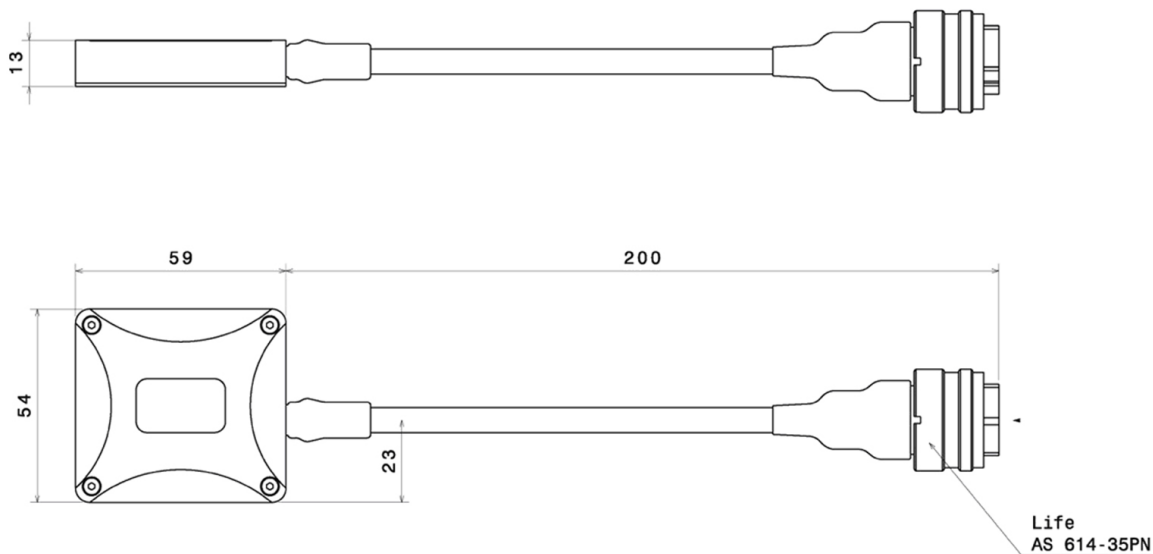

Represented by:

Europe:
 Bosch Engineering GmbH
 Motorsport
 Robert-Bosch-Allee 1
 74232 Abstatt
 Germany
 motorsport@bosch.com
 www.bosch-motorsport.de

North America:
 Bosch Engineering North America
 Motorsport
 38000 Hills Tech Drive
 Farmington Hills, MI 48331-3417
 United States of America
 motorsport@bosch.com
 www.bosch-motorsport.com

Asia-Pacific:
 Bosch Engineering Japan K.K.
 Motorsports Department
 1-9-32 Nakagawachuo, Tsuzuki-ku
 Yokohama-shi
 Kanagawa, 224-8601
 Japan
 motorsport@jp.bosch.com
 www.bosch-motorsport.jp

Australia, New Zealand and South Africa:
 Robert Bosch Pty. Ltd
 Motorsport
 1555 Centre Road
 Clayton, Victoria, 3168
 Australia
 motor.sport@au.bosch.com
 www.bosch-motorsport.com.au